



City of Crystal Lake

BUILDING CODES 2018

FEBRUARY 20, 2018 CITY COUNCIL MEETING

Key Enhancements

Provide for additional safety features in new construction

Provide new methods for compliance and materials

Provide additional information to contractors for specific project types

Key Points

- ❖ Specific section for fire protection of floors in single family homes constructed without sprinklers
- ❖ Specific section providing details on deck construction
- ❖ More flexibility for property owners in reuse of existing buildings
- ❖ 2018 Codes to be effective 6 months after approval

Example

Underside of floors in basements to have:

- ½" drywall
- Limited area sprinkler
- 2x10 or greater wood members

Example

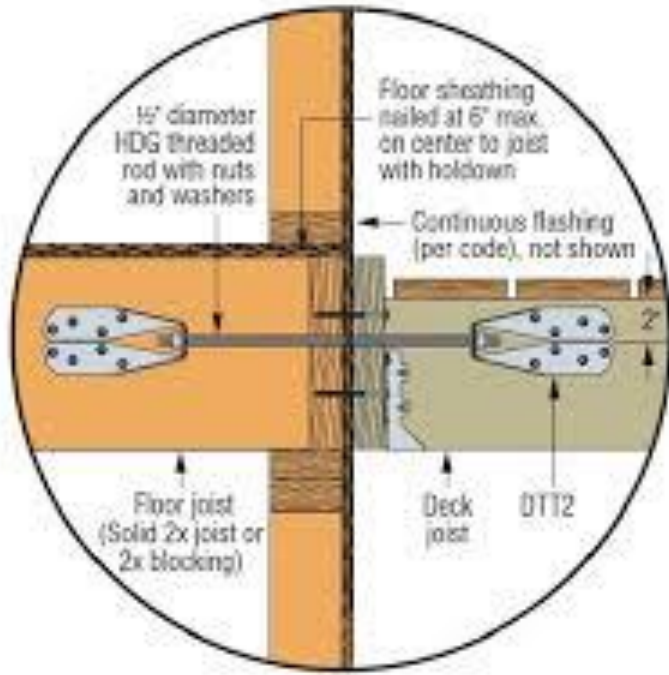

Typical Deck-to-House
Lateral Load Connection

Lateral Load Connection Device: Simpson Strong-Tie DTT1

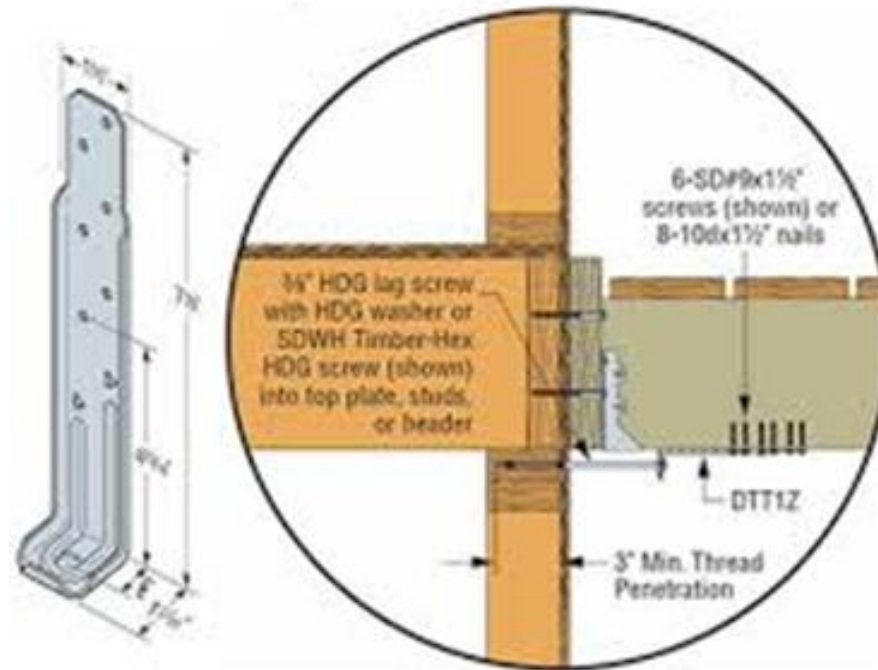

Example

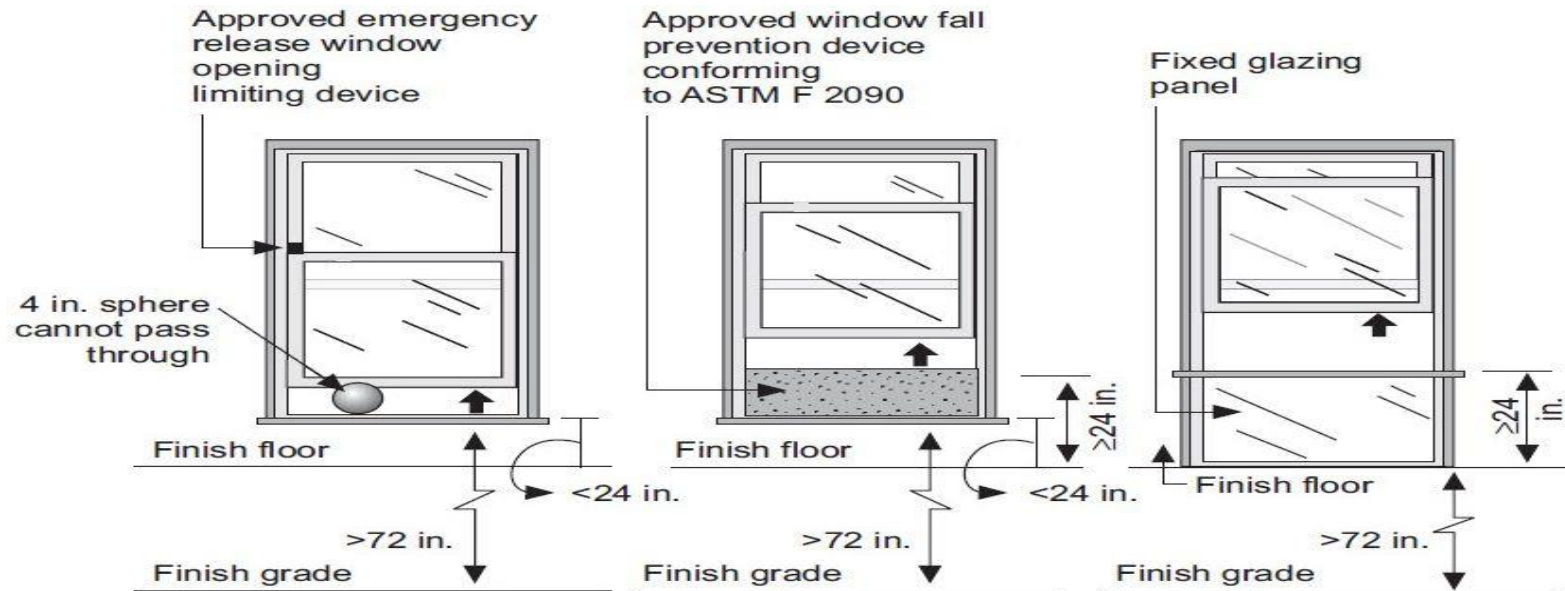

For SI: 1 inch = 25.4 mm.

Window sill height



Process

- ❖ Public Outreach
 - ✓ Posted on website
 - ✓ Two Open Houses
 - ✓ Chamber of Commerce
- ❖ Adoption at March 20th City Council meeting
- ❖ Effective 6 months later (October 2018).