

# RIGHT-OF-WAY DESIGN MANUAL

---

June 26, 2019

---

City of Crystal Lake



---

# Contents

Background, Purpose, and Authority .....	4
Background .....	4
Purpose .....	4
Authority .....	5
Definitions .....	5
General Design Guidelines .....	6
Right to Reserve Space.....	6
Structure – Utility Pole .....	6
Structure – Street Light Pole .....	7
Structure – Pole Mounted Equipment .....	8
Structure – Ground Mounted Equipment.....	9
Context Specific Design Guidelines by District.....	10
Downtown Crystal Lake District .....	11
Structure – Utility Pole .....	11
Structure – Street Light Pole .....	12
Structure – Ground Mounted Equipment.....	12
Virginia Street Corridor District.....	13
Structure – Utility Pole .....	13
Structure – Street Light Pole .....	14
Structure – Ground Mounted Equipment.....	16
Three Oaks Recreation Area District .....	17
Structure – Utility Pole .....	17
Structure – Street Light Pole .....	18
Structure – Ground Mounted Equipment.....	20
Residential Districts.....	21
Structure – Utility Pole .....	21
Structure – Street Light Pole .....	22
Structure – Ground Mounted Equipment.....	22
Other Business/Commercial Districts .....	23
Structure – Utility Pole .....	23
Structure – Street Light Pole .....	24
Structure – Ground Mounted Equipment.....	24

---

Modifications to Design Guidelines .....	24
Appeals.....	25
Appendix I – Composite/Fiberglass Utility Pole Sample .....	26
Appendix II – ComEd Detail C9075.....	27
Appendix III – Downtown Crystal Lake District Detail.....	28
Appendix IV – Virginia Street Corridor Detail.....	29
Appendix V – Three Oaks Recreation Area Detail.....	30
Appendix VI – Street Light Design with Internal Cabinet.....	31

---

# Background, Purpose, and Authority

## Background

The City of Crystal Lake has provided various rules and regulations for right-of-way apparatuses, utilities, and telecommunications facilities, including small cell wireless facilities.

The Unified Development Ordinance, Chapter 650 of the Crystal Lake City Code was adopted April 21, 2009. The Unified Development Ordinance provides standard cross-sections for streets, the Access Management Manual, Virginia Street Design Guidelines, standard details, pavement design and construction, and sidewalk design and construction.

Chapter 427 of the Crystal Lake City Code establishes policies and procedures for constructing facilities on rights-of-way within the City's jurisdiction to provide public benefits consistent with the preservation of the integrity, safe usage, and visual qualities of the City rights-of-way and the City as a whole

At the July 17, 2018 City Council meeting, in response to Public Act 100-0585, the Crystal Lake City Council adopted an Ordinance providing for the regulation and permitting of small wireless facilities. After the City's adoption of its small wireless facility regulations, the Federal Communications Commission ("FCC") issued a "Declaratory Ruling and Third Report and Order" and a final federal rulemaking (collectively the "FCC Order"). Subsequently, at the January 15, 2019 City Council meeting, the City Council approved an amendment to the Ordinance in response to the FCC Order.

Chapter 428 of the Crystal Lake City Code has been approved to account for the provisions of Public Act 100-0585 and the FCC Order regarding regulation of small cell facilities and support structures within City rights-of-way. Consistent with State and federal law, Chapter 428 of the City Code implements that City's authority to manage access to and occupancy of rights-of-ways with regard to matters of local concern while accommodating deployment of small cell infrastructure. This includes the protection of the integrity of residential and historic areas and ensures that the use of the rights-of-way in such districts is technologically and aesthetically appropriate.

At the June 18, 2019 City Council meeting, Chapters 427 and 428 of the City Code were amended to authorize and reference this Right-of-Way Design Manual. The purpose of this Manual is to provide guidelines for the implementation and administration of Chapters 427 and 428 of the City Code when new facilities are constructed within City rights-of-way. The design guidelines within this document must be met, unless otherwise approved by the City's Director of Public Works in accordance with this Manual or otherwise required by law.

## Purpose

This design manual provides design guidelines for above-ground facilities and structures within all rights-of-way under the jurisdiction of the City of Crystal Lake. The design manual provides for structures to match the character of the existing area or neighborhood in which they are located. Design standards will correlate with the specific areas of the City. The City is divided into the following districts: Downtown, Virginia Street Corridor, Residential Districts, Three Oaks Recreation Area, and Other Business/Commercial Districts.

---

The objective of the design manual is to strike a balance between accommodating expansion of facilities and technology within rights-of-way and preserving the character and aesthetics of the City of Crystal Lake through careful design, siting, landscaping and camouflaging techniques to blend facilities within the right-of-way into their environment.

These guidelines apply to all requests to locate facilities within the right-of-way, including pole-mounted equipment, ground-mounted equipment, small cell wireless facilities, poles, and other structures, except as otherwise required by law.

## Authority

This Right-of-Way Design Manual ("Manual") is adopted by the City of Crystal Lake's Director of Public Works pursuant to Sections 427-15(H) and 428-3(B)(1)(m) of the Crystal Lake City Code.

## Definitions

### **FACILITY**

All structures, devices, objects, and materials (including, but not limited to, track and rails, wires, ducts, fiber-optic cable, antennas, small wireless facilities, vaults, boxes, equipment enclosures, cabinets, pedestals, poles, conduits, grates, covers, pipes, cables, and appurtenances thereto) located on, over, above, along, upon, under, across, or within rights-of-way pursuant to Chapters 427 and/or 428 of the City Code.

### **GROUND MOUNTED EQUIPMENT**

All structures, equipment enclosures, cabinets and pedestals located on the ground within the right-of-way that are accessory to pole mounted equipment or serve facilities within the right-of-way.

### **POLE MOUNTED EQUIPMENT**

All secondary structures or devices that are attached to street light poles or utility poles which are not part of the original structure.

### **SMALL WIRELESS FACILITY**

A "small wireless facility" as defined in Section 428-2 of the City Code.

### **RIGHT-OF-WAY or RIGHTS-OF-WAY**

Any street, alley, other land or waterway, dedicated or commonly used for pedestrian or vehicular traffic or other similar purposes, including utility easements, in which the City has the right and authority to authorize, regulate or permit the location of facilities other than those of the City. "Right-of-way" or "Rights-of-way" shall not include any real or personal City property that is not specifically described in the previous two sentences and shall not include City buildings, fixtures and other structures or improvements, regardless of whether they are situated in the right-of-way.

---

## **STREET LIGHT POLE**

A structure with one or more luminaires or light installations designed to illuminate a public roadway, pedestrian facility, intersection, or other right-of-way.

## **STREET LIGHT POLE WITH INTERNAL CABINET**

A structure with one or more luminaires or light installations designed to illuminate a public roadway, pedestrian facility, intersection, or other right-of-way which also incorporates an equipment cabinet within the base of the pole to allow for the addition of secondary devices, equipment, or technology within the pole.

## **UTILITY POLE**

A pole or similar structure that is used in whole or in part by a utility provider or communications service provider for electric distribution, telecommunications, or a similar function, including a pole or similar structure that is designed and installed primarily to support one or more small wireless facilities.

# General Design Guidelines

The following design guidelines apply to all facilities within all rights-of-way under the jurisdiction of the City of Crystal Lake, unless otherwise agreed or required by applicable law. Signage is prohibited on all facilities within the right-of-way, including stickers, logos, text, and other non-essential graphics and information other than the owner identification unless required by State or federal law or regulations.

## Right to Reserve Space

The City may reserve space in accordance with the City Code for future public safety, utility, or transportation uses in the right-of-way or on a City-owned utility pole.

## Structure – Utility Pole

The Unified Development Ordinance, Chapter 650, Article 5-200 Subdivisions requires that public utilities be located underground, unless a deferral is granted. Notwithstanding, any new utility pole must meet the following requirements:

### *Height Limitations*

- Any new pole shall not exceed the height of the existing utility poles in the immediate area, except as otherwise permitted under Section 428-3(B)(1)(a) of the City Code.

### *Location and Spacing*

- Any new pole shall be installed in a dedicated Public Utility Easement (PUE) to the extent feasible and comply with Chapters 427 and 428 of the City Code.
- Preferred Alignment: The centerline of new utility poles shall be installed in alignment with existing poles where present, or with street trees along the same side of the right-of-way, unless otherwise required in the Context Specific Design Guidelines found later in this document.
- In no case shall any portion of new utility pole be located less than two feet from the travel way, edge line, face of curb, sidewalk, bike lane, or shared-use path.

- New utility poles shall comply with the spacing requirements set forth in Chapters 427 and 428 of the City Code.
- New utility poles shall be located midway between any immediately adjacent existing utility poles on either side of the proposed new pole to the maximum extent possible.
- New utility poles shall be located a minimum of twelve (12) feet from any existing permanent object, existing lawful encroachment, or driveway apron in the right-of-way to allow for access.
- New utility poles shall be located outside of intersection sight distance triangles, whenever possible. Please refer to:  
[Access Management Manual: https://www.crystallake.org/home/showdocument?id=9364](https://www.crystallake.org/home/showdocument?id=9364)
- New utility poles shall be sited outside of the critical root zone of existing street trees and any existing protected trees having a six (6) inch or greater diameter at breast height (DBH) located in the immediate vicinity, including protected trees on private property as defined in the [City of Crystal Lake Tree Preservation Ordinance: https://www.crystallake.org/our-community/green-initiatives/tree-preservation](https://www.crystallake.org/our-community/green-initiatives/tree-preservation)
- If multiple requests are received to install two or more new poles that would violate the applicable spacing requirements, then the first complete application filed will be given priority.

### ***Style and Condition***

- All new poles shall be a decorative composite or fiberglass pole, *see* Appendix I.
- All poles must be properly maintained.

## **Structure – Street Light Pole**

Street lights within the City of Crystal Lake are serviced by ComEd. In cooperation with ComEd, and except as otherwise indicated in this Design Manual for specific districts within the City, the standard street light pole is the Fiberglass Decorative Street Lighting in gray, *see* ComEd detail in Appendix I.

### ***Height Limitations***

- Any new pole shall not exceed the height of the existing utility poles in the immediate area and shall comply with the height and design requirements of the district in which it is located, except as otherwise permitted under Section 428-3(B)(1)(a) of the City Code.

### ***Location and Spacing***

- Any new pole shall be installed in a dedicated public street right-of-way and comply with Chapter 427 of the City Code.
- Preferred Alignment: The centerline of new street light poles shall be installed in alignment with existing street light poles where present, or with street trees along the same side of the right-of-way, unless otherwise required in the Context Specific Design Guidelines found later in this document.
- In no case shall any portion of a new street light pole be located less than two feet from the travel way, edge line, face of curb, sidewalk, bike lane, or shared-use path.
- New street light poles shall comply with the spacing requirements set forth in the City Code.
- New street light poles shall be located midway between any immediately adjacent existing street light poles on either side of the proposed new pole to the maximum extent possible.

- 
- New street light poles shall be located a minimum of twelve (12) feet from any existing permanent object, existing lawful encroachment, or driveway apron in the right-of-way to allow for access.
  - New street light poles shall be located outside of intersection sight distance triangles, whenever possible. Please refer to:  
[Access Management Manual: https://www.crystallake.org/home/showdocument?id=9364](https://www.crystallake.org/home/showdocument?id=9364)
  - New street light poles shall be sited outside of the critical root zone of existing street trees and any existing protected trees having a six (6) inch or greater diameter at breast height (DBH) located in the immediate vicinity, including protected trees on private property as defined in the [City of Crystal Lake Tree Preservation Ordinance: https://www.crystallake.org/our-community/green-initiatives/tree-preservation](https://www.crystallake.org/our-community/green-initiatives/tree-preservation)
  - If multiple requests are received to install two or more new street light poles that would violate the applicable spacing requirements, then the first complete application filed will be given priority.

### ***Style and Condition***

- All new poles shall be the standard Fiberglass Decorative Street Lighting in gray, *see* Appendix II, except as otherwise provided in this Design Manual for specific districts within the City.
- All poles shall be properly maintained.
- All poles shall be kept free of signage, unless otherwise required by law.

## **Structure – Pole Mounted Equipment**

A structure mounted to a utility pole, street light pole, or other pole or support structure within the right-of-way must adhere to the following requirements:

### ***Height Limitations***

- No portion of a facility shall extend more than 10 feet above the pole or other structure to which it is attached.
- No pole-mounted equipment shall be installed or maintained on a pole or other structure at a height less than 15 feet above the adjacent grade.

### ***Required Setbacks***

- Equipment shall be placed so as not to impede or impair public safety or the legal use of the right-of-way by the traveling public.
- Encroachments Prohibited: Equipment may not encroach at grade or within the airspace beyond the right-of-way or over the travelway.

### ***Cabling and Wiring***

- Cables and other wiring serving pole-mounted equipment shall be enclosed in conduit flush-mounted to the supporting pole. Conduit shall be finished to match the materials, texture, and color of the subject pole.



---

## Design

- Pole-mounted equipment shall be painted, textured, and designed in a manner consistent with the pole's style, color, texture and materials and otherwise camouflaged and designed to blend in with the existing pole such that the attached facility is no more readily apparent or plainly visible (as reasonably determined by the City's Director of Public Works) than any other existing equipment located on the pole.
- If the supporting pole is visible (at ground level) from and within 50 feet of any residential structure, facilities shall be concealed or screened by means of canisters, radomes, shrouds or other similar concealment enclosures, which shall be flush-mounted to the pole and painted, textured, and designed in a manner consistent with the pole's style, color, texture and materials and otherwise camouflaged and designed to blend in with the existing pole.

## Structure – Ground Mounted Equipment

Ground mounted equipment should only be utilized in extreme circumstances in replacement of buried utilities. Above-ground equipment and equipment cabinets or enclosures associated with utilities mounted to poles must adhere to the following requirements:

- Siting Requirements. Ground-mounted equipment shall be: (i) integrated into the base of an existing utility pole or street light pole; (ii) integrated into the base of a new or replacement utility pole or street light pole that meets the applicable siting requirements for such poles; or (iii) located within a cabinet or other similar enclosure that is physically independent from a utility or street light pole and sited in accordance with the following requirements:
  - Ground-mounted equipment enclosures shall be located no closer than five feet (5') from the edge of any pavement on a street with curbing, and no closer than ten feet (10') feet from the edge of any pavement on a street without curbing. In no event shall ground-mounted equipment enclosures be located within a drainage ditch.
  - Ground-mounted equipment enclosures shall be located a minimum of twelve (12) feet from any permanent object or existing lawful encroachment in the right-of-way to allow for access.
  - Ground-mounted equipment enclosures shall not be sited in conflict with required intersection sight distance triangles. Please refer to [Access Management Manual: https://www.crystallake.org/home/showdocument?id=9364](https://www.crystallake.org/home/showdocument?id=9364)
  - Ground-mounted equipment enclosures shall be located a minimum of twelve (12) feet from driveway aprons as measured parallel to the right-of-way.
- Encroachments Prohibited
  - No portion of any ground-mounted equipment or associated cabinet or enclosure may encroach at grade or within the airspace beyond the right-of-way or over the travelway.
- Design Specifications
  - Attachment to Foundation/Slab: Cabinets and other equipment enclosures must be secured to a concrete foundation or slab with a break-away design in the event of collisions.
  - Owner Identification. A four (4) inch by six (6) inch (maximum) plate with the owner's name, location, identifying information, and emergency telephone number shall be permanently fixed to the cabinet or enclosure.

- 
- Additional Landscape Screening
    - Screening of ground-mounted equipment and enclosures with evergreen plant material is required, consistent with the landscape character of the surrounding area.
    - All landscaping proposed within the right-of-way shall be reviewed for appropriateness of the proposed planting plan and plant specifications by the City of Crystal Lake’s Arborist.
  - Screening and Installation Location. All ground-mounted equipment shall be completely concealed from view within the cabinet or enclosure.
  - Cables and other wiring serving ground-mounted equipment shall be enclosed within the cabinet or in conduit flush mounted to the cabinet or other support structure. Conduit shall be finished to match the materials, texture, and color of the subject structure.
  - Color and Design
    - To ensure consistency among right-of-way infrastructure, all cabinets integrated within the transformer base of a pole shall match the style, color, texture, materials, and design of the associated pole as prescribed in the Context Specific Design Guidelines, or as otherwise approved by the Director of Public Works, or his/her designee. Ground-mounted cabinets that are physically independent from a utility pole or street light pole shall be consistent with the style, color, and design of existing poles or equipment within the area as reasonably determined by the City Engineer.

## Context Specific Design Guidelines by District

The design and character of the right-of-way in the City of Crystal Lake is defined by a variety of interconnected factors—the most prevalent are the functional classification of the roadway within the right-of-way and the predominant land uses along the right-of-way. These variables influence the amount of space available in the right-of-way outside of the travel lanes for elements such as sidewalks and shared-use paths, street trees, street lights and utility infrastructure, as well as the aesthetic qualities of these elements.

The unique environmental aesthetics of each area, as well as the characteristics of the right-of-way itself must be taken into consideration in the deployment of new facilities. These facilities must blend seamlessly into the surrounding context to the maximum extent possible.

For the purposes of outlining context specific design guidelines for new facilities, poles, and other support structures, five districts have been defined based on the unique existing and desired character of the rights-of-way within these areas. These districts are:

- Downtown Crystal Lake
- Virginia Street Corridor
- Residential Districts
- Three Oaks Recreation Area
- Other Business/Commercial Districts

The boundaries of each district are depicted in the following figure. In addition to the General Design Guidelines described earlier in this document, the applicable Context Specific Guidelines set forth below must be met unless otherwise approved by the City’s Director of Public Works in accordance with this Manual or otherwise required by law. Where conflicts exist, the Context Specific Guidelines shall prevail over the General Design Guidelines.

**FIGURE 1: SUB-AREA DESIGN DISTRICTS**

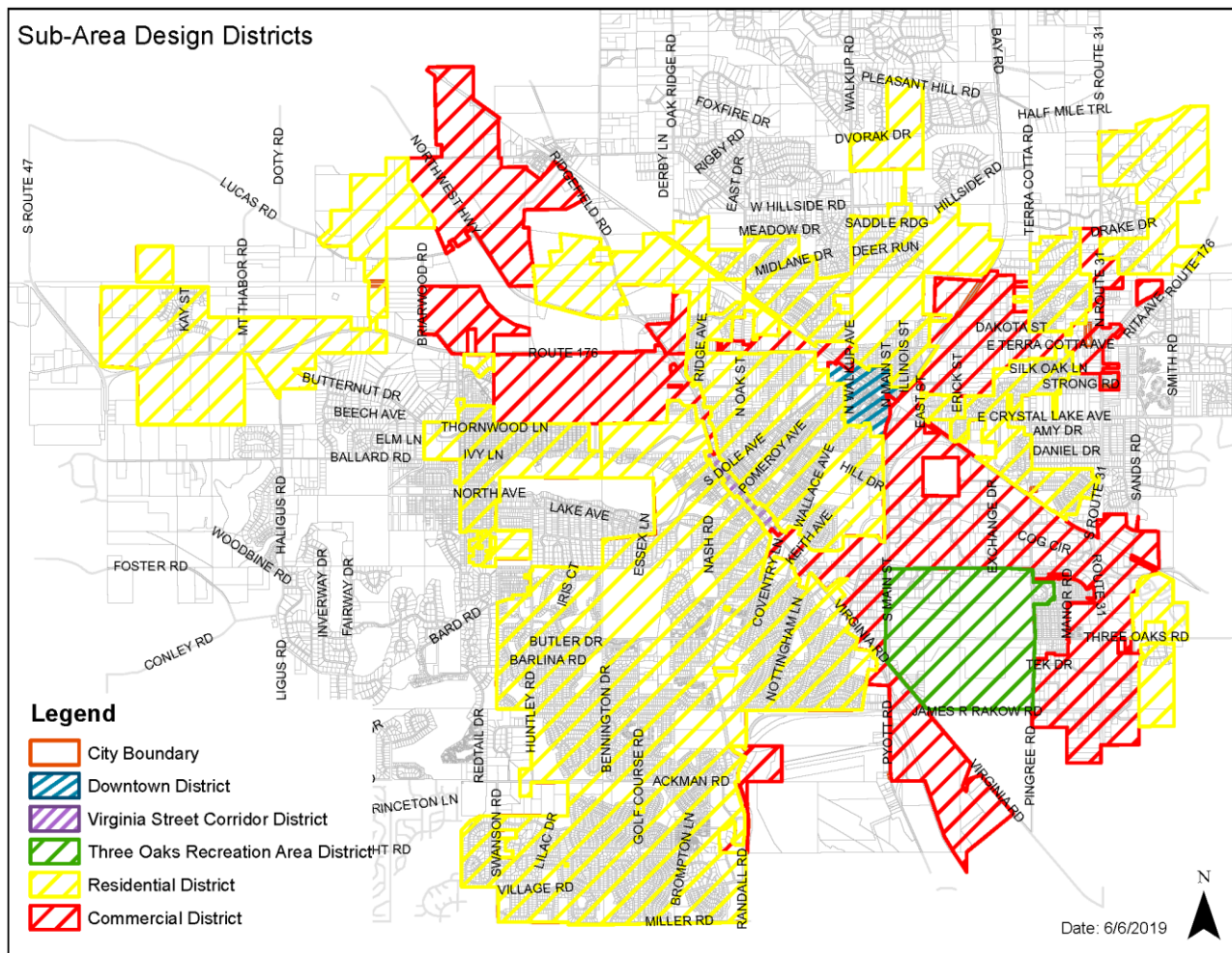

## Downtown Crystal Lake District

Downtown Crystal Lake is characterized by a pattern of small blocks accessed by a number of narrow streets and alleys that function as service streets at the rear of the lots and where a variety of existing above grade infrastructure is present. It is preferred that any pole mounted utility equipment be located on existing utility poles within this district as those are typically located in the rear of properties. It is highly discouraged to locate pole mounted equipment on street light poles.

## Structure – Utility Pole

### Height Limitations

- Any new pole shall not exceed the height of the existing utility poles in the immediate area, except as otherwise permitted under Section 428-3(B)(1)(a) of the City Code.

---

### ***Location***

- Existing utility poles within the Downtown Crystal Lake District are predominately located within the alleys and the rear of the buildings.
- Any new utility pole shall be installed in a dedicated Public Utility Easement (PUE) located within alleys or the rear of building to the extent feasible. New poles shall comply with Chapters 427 and 428 of the City Code and the requirements of this Manual.

### ***Style and Condition***

- All new poles must adhere to the provisions of the General Design Guidelines as well as the requirements outlined in this section.
- All new poles must be a flat black finish to match the character of the district.
- All poles shall be properly maintained.
- All poles shall be kept free of signage, unless otherwise required by law.

## **Structure – Street Light Pole**

The standard street light pole in Downtown Crystal Lake is the Acorn Style fiberglass street light, *see* Appendix III. Replacement street light poles must match the character and aesthetics of the standard street light seen in Appendix III. Replacement street light poles must be a Street Light Pole with an internal cabinet, *see* Appendix VI.

### ***Height Limitations***

- Street lights within the district must be 9 feet six inches in height, measured to the base of the acorn light fixture.

### ***Location***

- Street lights are to be located per the standards listed in Chapter 427 and 428 of the City Code and in this Manual.
- Decorative brick pavers that are removed or damaged in connection with street light installation, replacement, or modification must be replaced and match the existing paver bricks.

### ***Style and Condition***

- New or replacement street light poles shall conform with the standard Acorn Style fiberglass street light and include an internal cabinet.
- Street lights are to be painted a flat black.
- Acorn light fixtures are to have the proper shields within the light fixture.
- All poles shall be properly maintained.

## **Structure – Ground Mounted Equipment**

Ground mounted equipment is highly discouraged in this district. To the extent possible, facilities should be undergrounded. If pole mounted equipment requires ground mounted equipment that cannot be buried, an acceptable alternative is replace a Street Light Pole with a Street Light Pole with an internal cabinet. The replacement street light pole must match the aesthetics of the standard street light pole within this district. Any ground mounted equipment must adhere to the provisions of the General Design Guidelines previously stated.

## Virginia Street Corridor District

The Virginia Street Corridor (VSC) generally consists of all the parcels fronting the segment of Virginia Street (or Route 14) bound by 110 S Virginia St to the north (approximately 130 feet north of Carpenter Street) and 260 W Virginia St to the south (approximately 670 feet south of Linn Street). Also included are several properties fronting McHenry Avenue, King Street, and Florence Street. The VSC is held to the Virginia Street Design Guidelines found in Appendix A-100 of Chapter 650 Unified Development Ordinance of the City Code. It is preferred that any pole mounted utility equipment be located on utility poles within this district as those are typically located in the rear of properties. It is highly discouraged to locate pole mounted equipment on street light poles.

**FIGURE 2: VIRGINIA STREET CORRIDOR DISTRICT**

### Virginia Street Corridor District

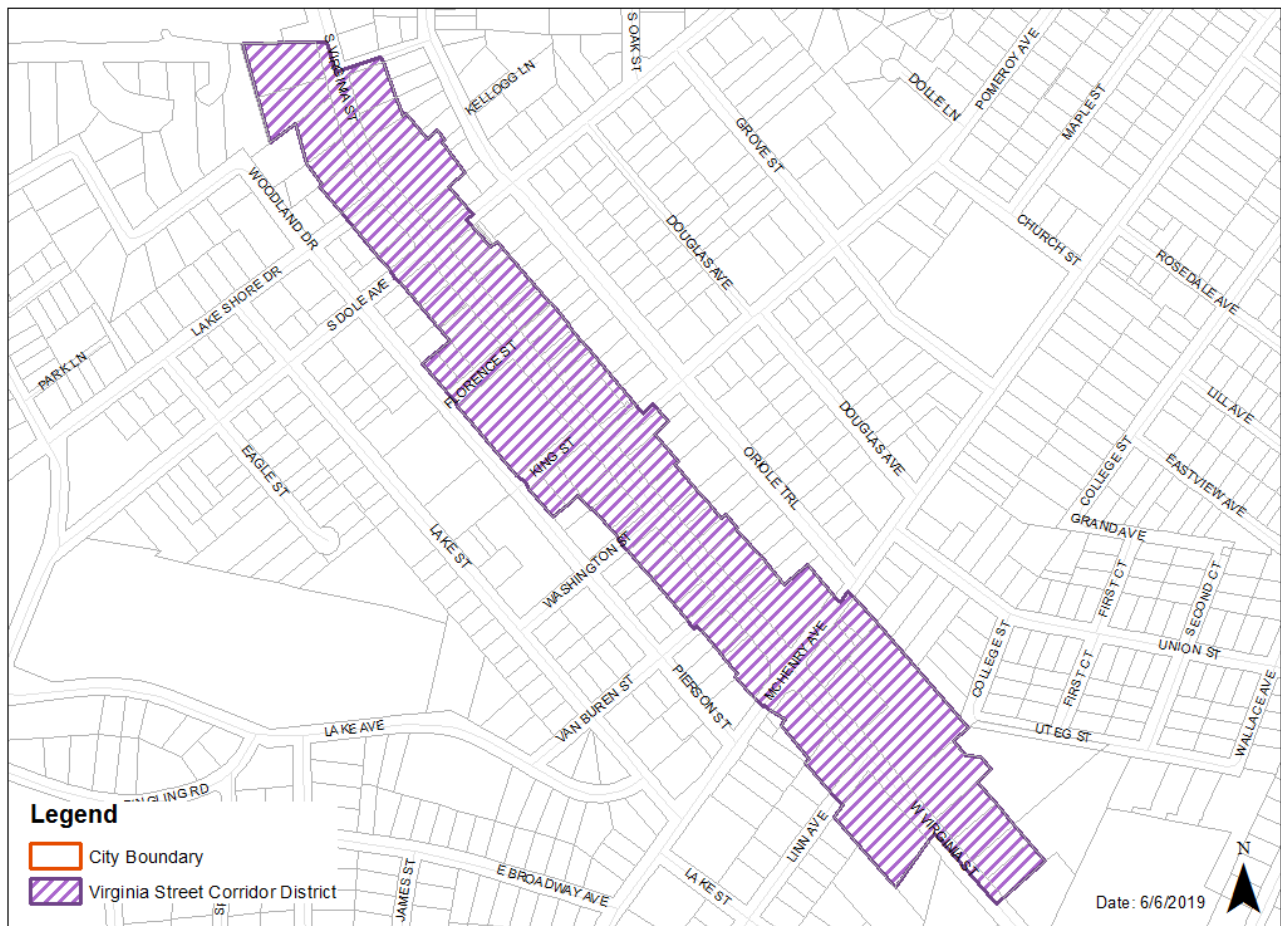

## Structure – Utility Pole

### *Height Limitations*

- Any new pole shall not exceed the height of the existing utility poles in the immediate area, except as otherwise permitted under Section 428-3(B)(1)(a) of the City Code.

---

### ***Location***

- Existing utility poles within the VSC district are predominately located within the rear of the properties.
- Any new utility pole shall be installed in a dedicated Public Utility Easement (PUE) located within alleys or the rear of the property to the extent feasible. New poles shall comply with Chapters 427 and 428 of the City Code and the requirements of this Manual.

### ***Style and Condition***

- All new poles must adhere to the provisions of the General Design Guidelines as well as the requirements outlined in this section.
- All new poles must be a flat black finish to match the character of the district.
- All poles shall be properly maintained.
- All poles shall be kept free of signage, unless otherwise required by law.

### **Structure – Street Light Pole**

The standard street light pole in the VSC district is a decorative fiberglass street light, as seen below in Figure 3 and Figure 4. Replacement street light poles must match the character and aesthetics of the standard street light seen in Appendix IV. Replacement street light poles must be a Street Light Pole with an internal cabinet, see Appendix VI.

### ***Height Limitations***

- Street light units within the district must be 32 feet 2 inches in height, measured to the base of the mast arm.
- Pedestrian level street light units within the district must be 17 feet in height, measured to the base of the mast arm.

### ***Location***

- Street lights are to be located per the standards listed in Chapters 427 and 428 of the City Code, the Virginia Street Corridor TIF plan, and this Manual.
- Decorative brick pavers that are removed or damaged in connection with street light installation, replacement, or modification must be replaced and match the existing paver bricks.

### ***Style and Condition***

- New or replacement street light poles shall conform with the standard decorative fiberglass street light (see Figures 3 and 4 as well as Appendix IV) and include an internal cabinet.
- Street lights are to be painted a smooth-finish black.
- All poles shall be properly maintained.

FIGURE 3: STREET LIGHT UNIT

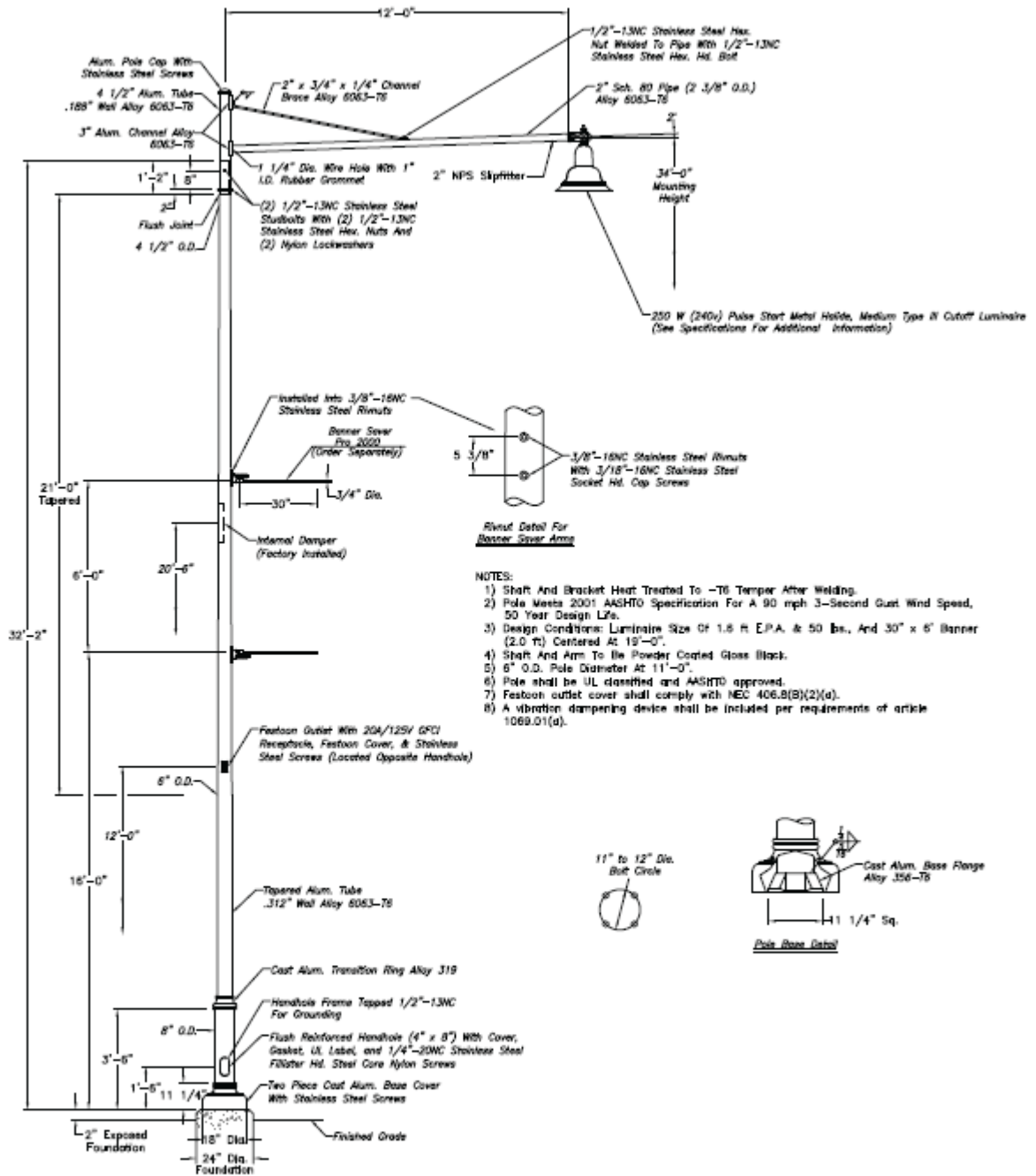

LIGHTING UNIT, TYPE 1 DETAIL

FIGURE 4: PEDESTRIAN LEVEL STREET LIGHT UNIT

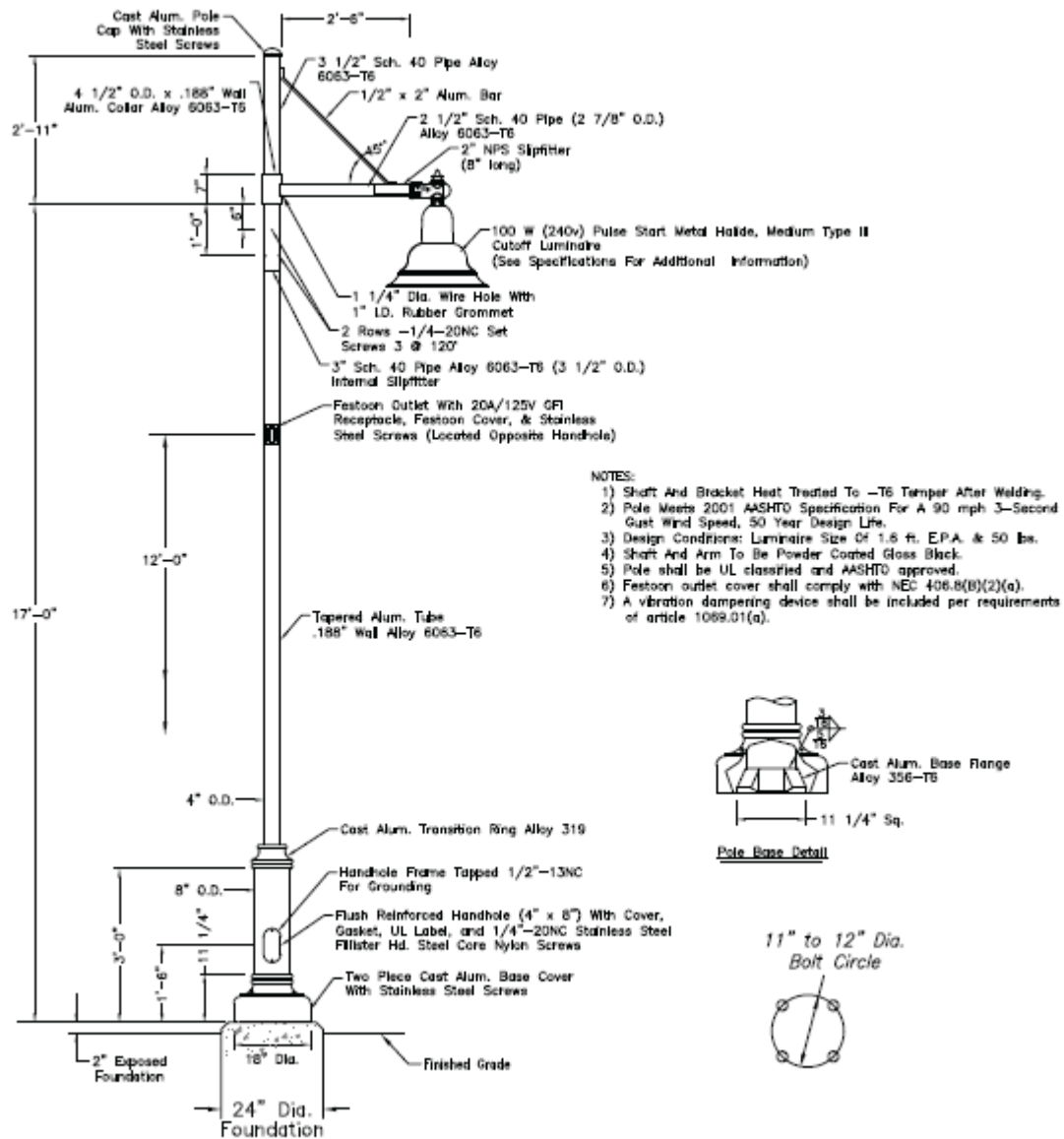

LIGHTING UNIT, TYPE 2 DETAIL

### Structure – Ground Mounted Equipment

Ground mounted equipment is highly discouraged in this district. To the extent possible, facilities should be undergrounded. If pole mounted equipment requires ground mounted equipment that cannot be buried, an acceptable alternative is replace a Street Light Pole with a Street Light Pole with an internal cabinet. The replacement street light pole must match the aesthetics of the standard street light pole within this district. Any ground mounted equipment must adhere to the provisions of the General Design Guidelines previously stated.



## Three Oaks Recreation Area District

The Three Oaks Recreation Area generally consists of all the parcels surrounding the lakes of the Three Oaks Recreation Area. Property that is included within the Three Oaks Recreation Area district should match the character of the park at Three Oaks Recreation Area. It is preferred that any pole mounted equipment be located on utility poles within this district as those are typically located in the rear of properties. It is highly discouraged to locate pole mounted equipment on street light poles.

### Three Oaks Recreation Area District

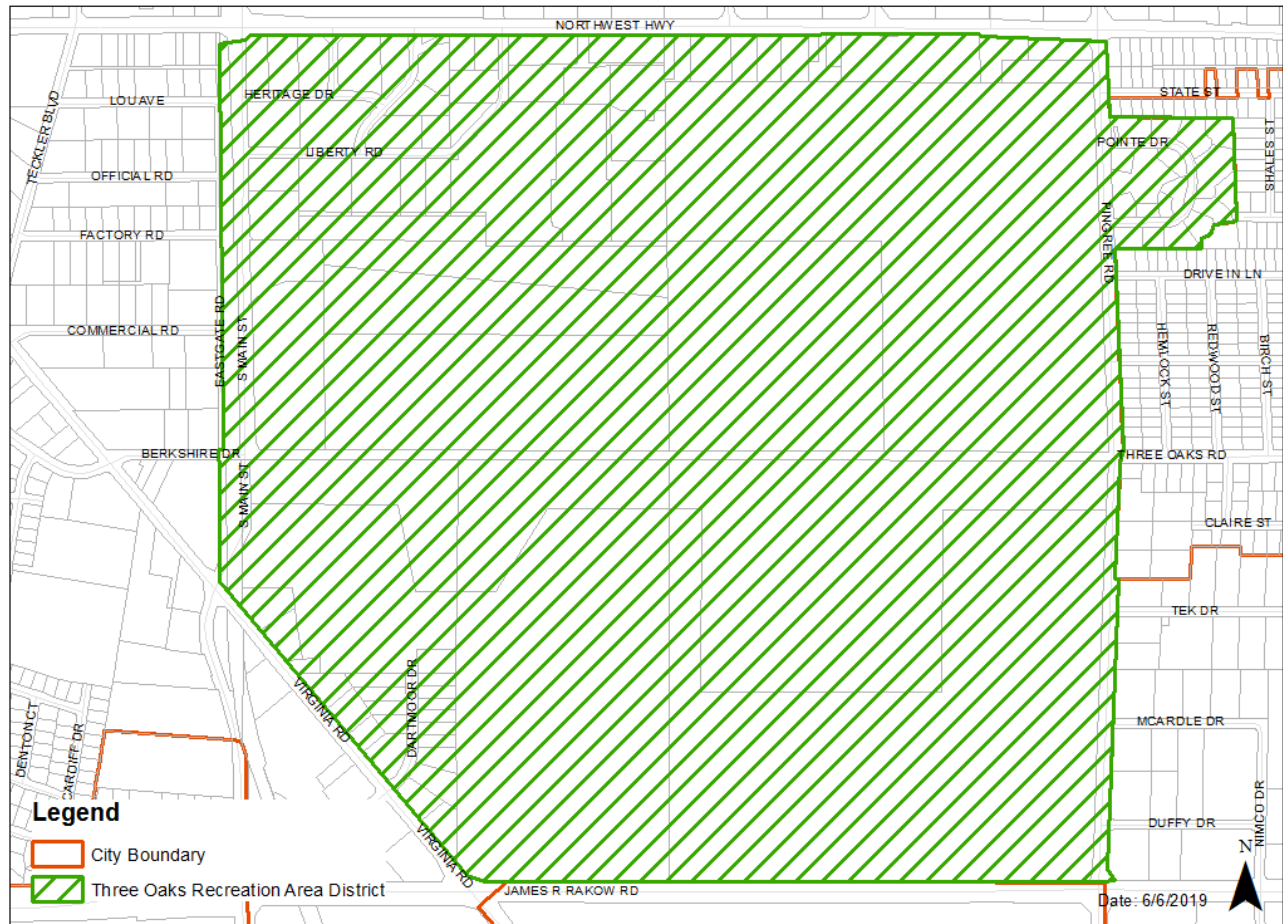

## Structure – Utility Pole

### *Height Limitations*

- Any new pole shall not exceed the height of the existing utility poles in the immediate area, except as otherwise permitted under Section 428-3(B)(1)(a) of the City Code.

### *Location*

- There are a limited amount of utility poles within the Three Oaks Recreation Area district. Pole-mounted equipment should be collocated on existing utility poles to the extent feasible.

- 
- Any new utility pole shall be installed in a dedicated Public Utility Easement (PUE) located within alleys or the rear of the property to the extent feasible. New poles shall comply with Chapters 427 and 428 of the City Code and the requirements of this Manual.

### ***Style and Condition***

- All new poles must adhere to the provisions of the General Design Guidelines as well as the requirements outlined in this section.
- All new poles must be a flat black finish to match the character of the district.
- All poles shall be properly maintained.
- All poles shall be kept free of signage, unless otherwise required by law.

### **Structure – Street Light Pole**

The standard street light pole in the Three Oaks Recreation Area district is a decorative fiberglass street light, as seen below in Figure 5 and Figure 6. Details for the street light poles can also be found in Appendix V. Replacement street light poles must match the character and aesthetics of the standard street light seen in Appendix V. Replacement street light poles must be a Street Light Pole with an internal cabinet, *see* Appendix VI.

### ***Height Limitations***

- Street light units within the district must be 32 feet 2 inches in height, measured to the base of the mast arm.
- Pedestrian level street light units within the district must be 16 feet in height, measure to the base of the mast arm.

### ***Location***

- Street lights are to be located per the standards listed in Chapters 427 and 428 of the City Code, the Vulcan Lakes TIF plan, and this Manual.
- Decorative brick pavers that are removed or damaged in connection with street light installation, replacement, or modification must be replaced and match the existing paver bricks.

### ***Condition***

- New or replacement street light poles shall conform with the standard decorative fiberglass street light (*see* Figures 5 and 6, as well as Appendix V) and include an internal cabinet.
- Street lights are to be painted a smooth-finish black.
- All poles shall be properly maintained.
- Pole mounted equipment must not interfere with the existing use and aesthetics of the pole, including City banners and hanging baskets.

FIGURE 5: STREET LIGHT UNIT

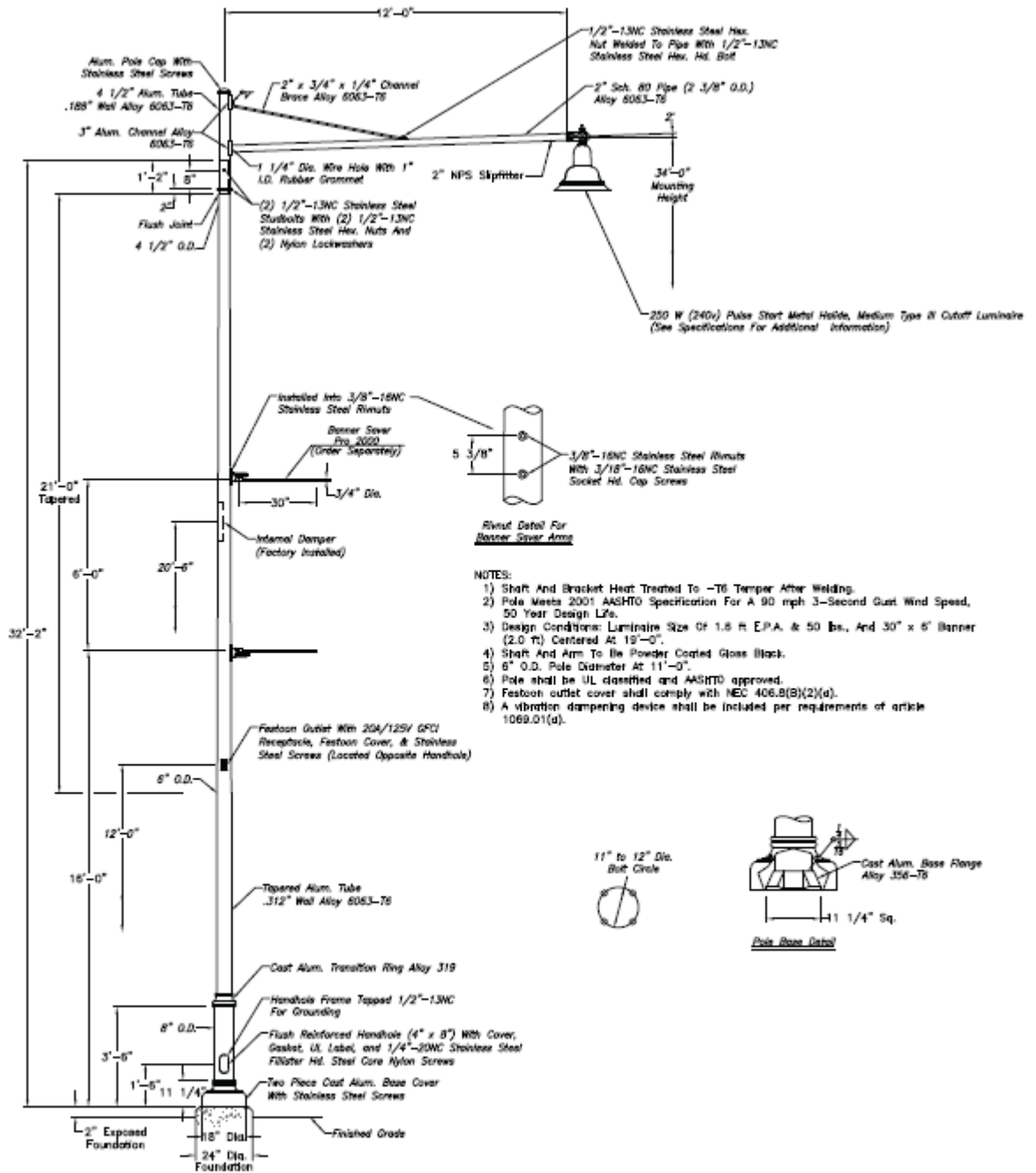

LIGHTING UNIT, TYPE 1 DETAIL

FIGURE 6: PEDESTRIAN LEVEL STREET LIGHT UNIT

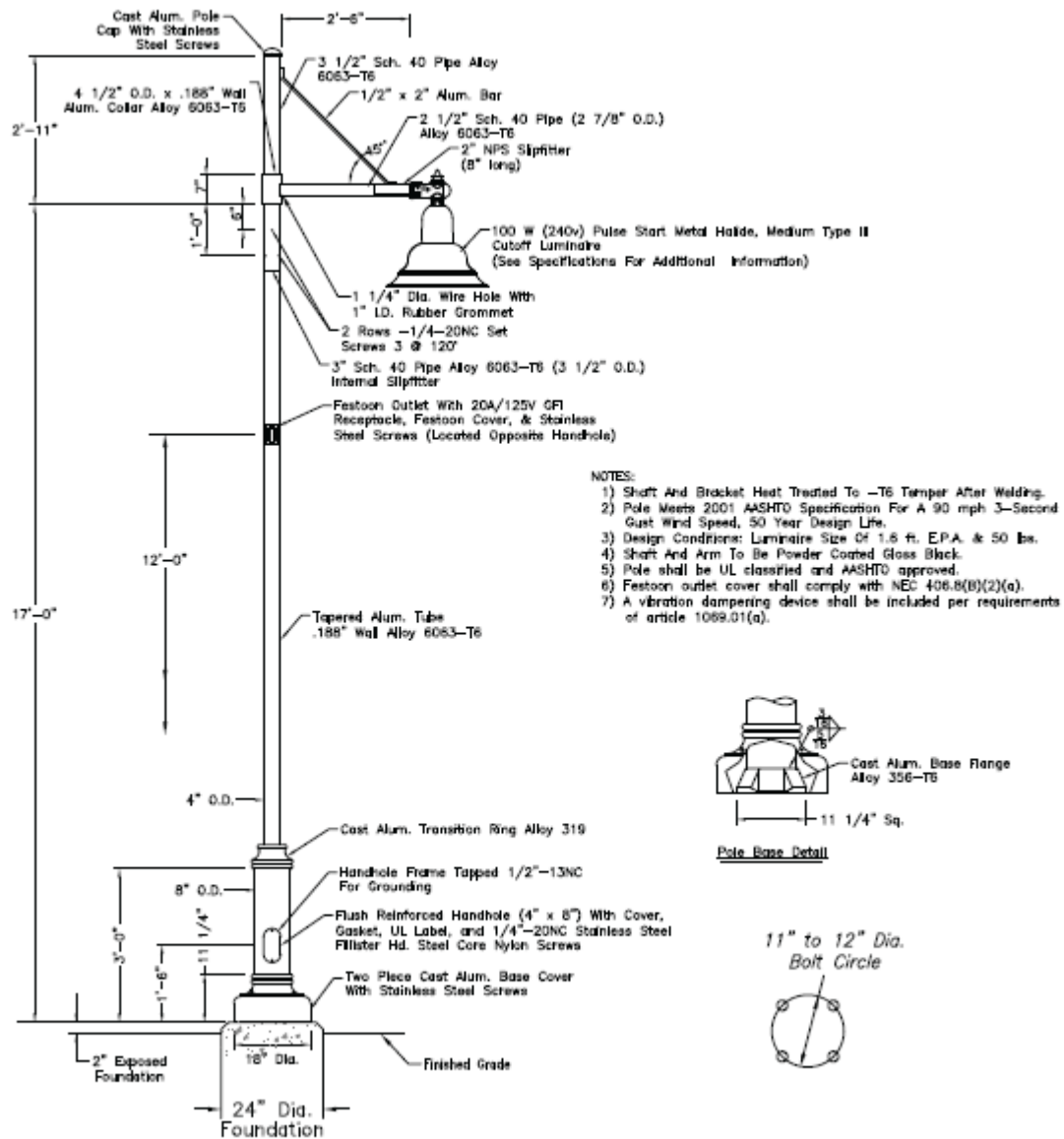

LIGHTING UNIT, TYPE 2 DETAIL

### Structure – Ground Mounted Equipment

Ground mounted equipment is highly discouraged in this district. To the extent possible, facilities should be undergrounded. If pole mounted equipment requires ground mounted equipment that cannot be buried, an acceptable alternative is replace a Street Light Pole with a Street Light Pole with an internal cabinet. The replacement street light pole must match the aesthetics of the standard street light pole within this district. Any ground mounted equipment must adhere to the provisions of the General Design Guidelines previously stated.

## Residential Districts

Residential districts are predominately single-family lots with front loading driveways. Within the residential districts, the majority of the street networks consist of local streets with minor collector streets.

Residential District

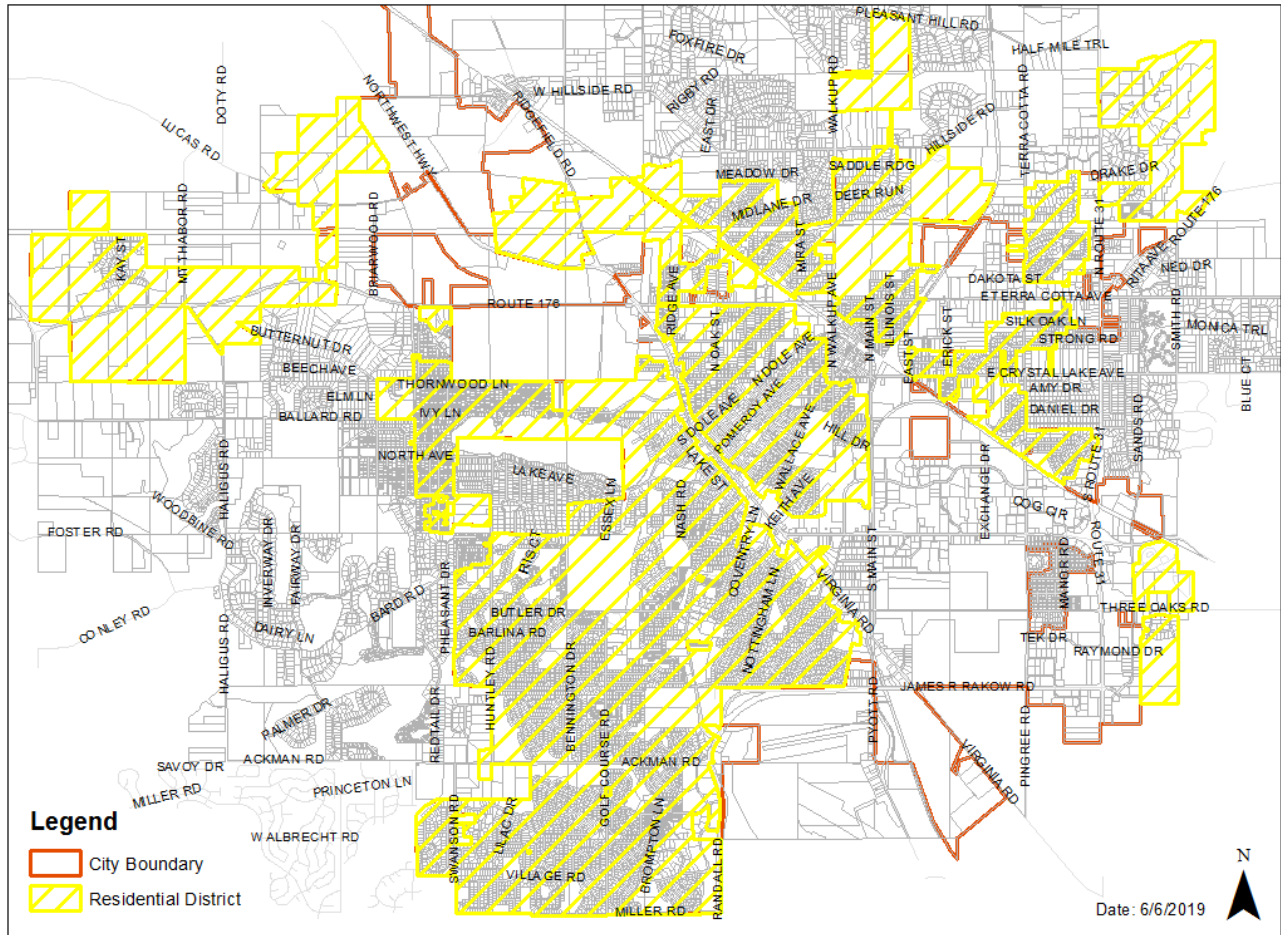

## Structure – Utility Pole

### Height Limitations

- Any new pole shall not exceed the height of the existing utility poles in the immediate area, except as otherwise permitted under Section 428-3(B)(1)(a) of the City Code.

### Location

- There are a limited amount of utility poles within the residential districts. Pole-mounted equipment should be collocated on existing utility poles to the extent feasible.
- Any new utility pole shall be installed in a dedicated Public Utility Easement (PUE) located within alleys or the rear of the property to the extent feasible. New poles shall comply with Chapters 427 and 428 of the City Code and the requirements of this Manual.

---

### ***Style and Condition***

- All new poles must adhere to the provisions of the General Design Guidelines as well as the requirements outlined in this section.
- All poles shall be properly maintained.
- All poles shall be kept free of signage, unless otherwise required by law.

### **Structure – Street Light Pole**

The standard street light poles in the residential districts are decorative fiberglass street lights, *see* Appendix II. There are a number of existing concrete decorative street lights. The concrete decorative street lights must be replaced with fiberglass decorative street lighting. Replacement street light poles must match the character and aesthetics of the standard street light seen in Appendix II. Replacement street light poles must be a Street Light Pole with an internal cabinet, *see* Appendix VI.

### ***Height Limitations***

- Street lights within the district must be 25 or 30 feet in height.

### ***Location***

- Street lights are to be located per the standards listed in Chapters 427 and 428 of the City Code and this Manual.
- Street lights are to be located at intersections and approximately every 300 feet.

### ***Style and Condition***

- New or replacement street light poles shall conform with the standard decorative fiberglass street light, *see* Appendix II, and include an internal cabinet.
- Street lights are to be a gray finish.
- All poles shall be properly maintained.

### **Structure – Ground Mounted Equipment**

Ground mounted equipment is highly discouraged in this district. To the extent possible, facilities should be undergrounded. If pole mounted equipment requires ground mounted equipment that cannot be buried, an acceptable alternative is replace a Street Light Pole with a Street Light Pole with an internal cabinet. The replacement street light pole must match the aesthetics of the standard street light pole within this district. Any ground mounted equipment must adhere to the provisions of the General Design Guidelines previously stated.

## Other Business/Commercial Districts

Business Neighborhoods and commercially zoned districts are predominantly served directly by arterial and collector streets.

### Other Business/Commercial District

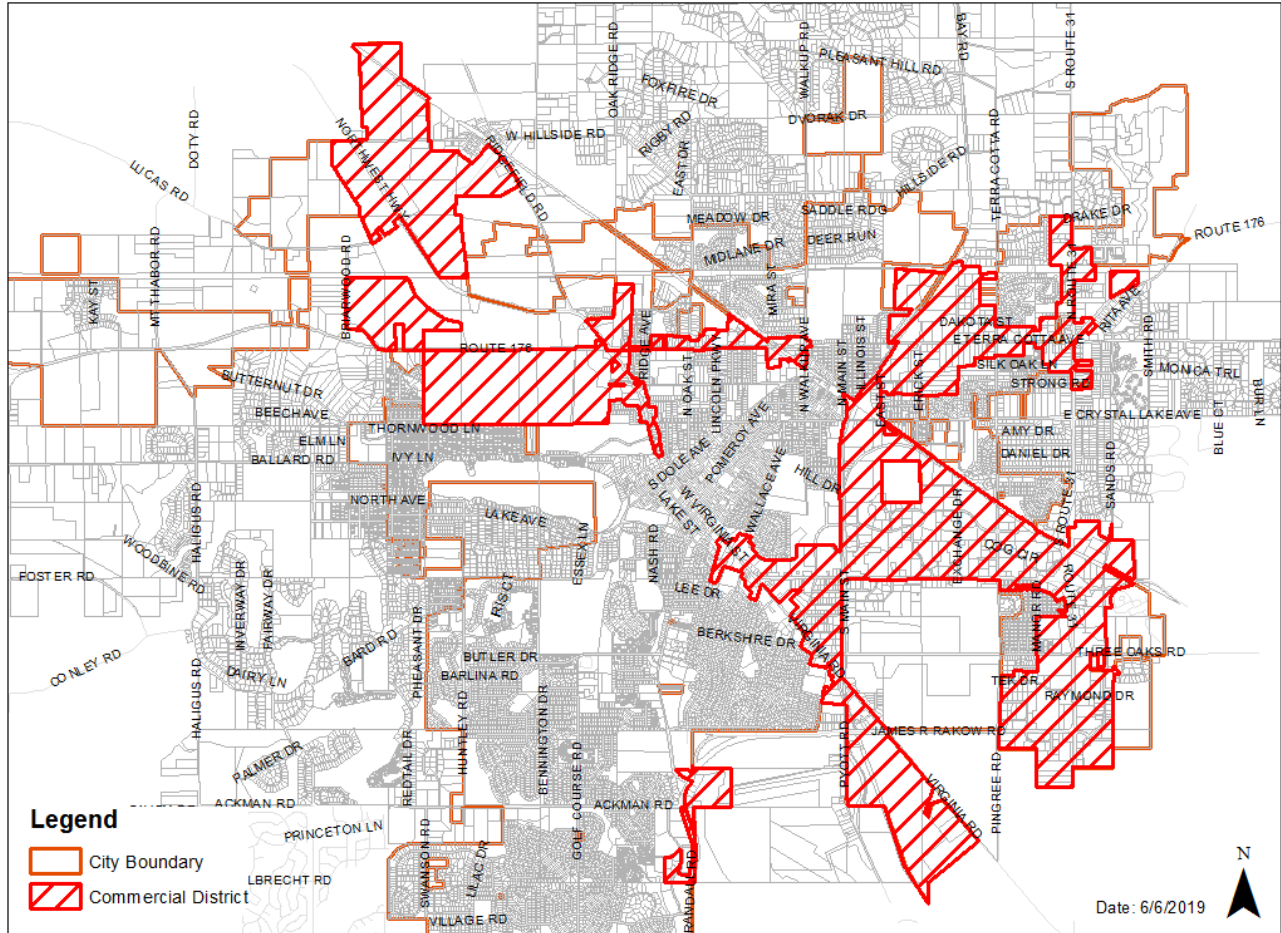

## Structure – Utility Pole

### Height Limitations

- Any new pole shall not exceed the height of the existing utility poles in the immediate area, except as otherwise permitted under Section 428-3(B)(1)(a) of the City Code.

### Location

- There are a limited amount of utility poles within the business/commercial districts. Pole-mounted equipment should be collocated on existing utility poles to the extent feasible.
- Any new utility pole shall be installed in a dedicated Public Utility Easement (PUE) located within alleys or the rear of the property to the extent feasible. New poles shall comply with Chapters 427 and 428 of the City Code and the requirements of this Manual.

---

### ***Style and Condition***

- All new poles must adhere to the provisions of the General Design Guidelines as well as the requirements outlined in this section.
- All poles shall be properly maintained.
- All poles shall be kept free of signage, unless otherwise required by law.

### **Structure – Street Light Pole**

The standard street light poles in the residential districts are decorative fiberglass street lights, *see* Appendix II. There are a number of existing concrete decorative street lights. The concrete decorative street lights must be replaced with fiberglass decorative street lighting. Replacement street light poles must match the character and aesthetics of the standard street light seen in Appendix II. Replacement street light poles must be a Street Light Pole with an internal cabinet, *see* Appendix VI.

### ***Height Limitations***

- Street lights within the district must be 25 or 30 feet in height.

### ***Location***

- Street lights are to be located per the standards listed in Chapters 427 and 428 of the City Code and this Manual.
- Street lights are to be located at intersections and approximately every 300 feet.

### ***Style and Condition***

- New or replacement street light poles shall conform with the standard decorative fiberglass street light (*see* Appendix II) and include an internal cabinet.
- Street lights are to be a gray finish.
- All poles shall be properly maintained.
- Pole mounted equipment must not interfere with the existing uses and aesthetics of the pole, including City banners.

### **Structure – Ground Mounted Equipment**

Ground mounted equipment is highly discouraged in this district. To the extent possible, facilities should be undergrounded. If pole mounted equipment requires ground mounted equipment that cannot be buried, an acceptable alternative is replace a Street Light Pole with a Street Light Pole with an internal cabinet. The replacement street light pole must match the aesthetics of the standard street light pole within this district. Any ground mounted equipment must adhere to the provisions of the General Design Guidelines previously stated.

## **Modifications to Design Guidelines**

A permit applicant seeking to locate a facility, pole, or other structure within the City's right-of-way may request a modification of one or more of the design guidelines established by this Manual by submitting a written request to the City's Director of Public Works in connection with such permit application. The request shall identify the guideline(s) for which a modification is requested and the reasons why modification is appropriate. The City's Director of Public Works shall decide whether modification is appropriate on an individual basis. No modification shall be approved pursuant hereto if it is inconsistent with a requirement of the City Code or any



---

ordinance of the City. See City Code §§ 427-21 and 428-6 regarding procedures of requesting variations from the requirements of Chapters 427 and 428, respectively, of the City Code. In considering a request for a modification of the design guidelines established by this Manual, the Director of Public Works shall consider whether:

- One or more conditions not under the control of the applicant creates a special hardship that would make compliance with the design guideline unreasonable or technically infeasible, given the public purposes to be achieved by this Manual; and
- Other designs, methods, materials, locations or facilities that would conform to the guideline for which modification is requested are impracticable or technically infeasible in relation to the requested approach.

As a condition for approving a design modification, the Director of Public Works may require the applicant to meet reasonable standards and conditions that may or may not be expressly contained within this Manual but which carry out the purposes and intent of this Manual in connection with the modification.

## Appeals

Any person or entity aggrieved by any order, requirement, decision, or determination, including but not limited to denial of or conditions established in connection with a requested design modification under this Manual may seek a review of such order, requirement, decision or determination by filing a request for review thereof in accordance with Section 427-21(E) or Section 428-7 of the City Code.

---

## Appendix I – Composite/Fiberglass Utility Pole Sample



**CREATIVE  
PULTRUSIONS**



**POWERTRUSION  
PRODUCTS**

Manufactured by Creative Pultrusions, Inc.  
www.powertrusion.com

PRODUCT BROCHURE

# COMPOSITE UTILITY POLES

ELECTRICAL DISTRIBUTION & TRANSMISSION



Creative Pultrusions, Inc. reserves the right to edit and modify literature, please consult the web site for the most current version of this document.

**PROVIDING  
LEADERSHIP IN  
ADVANCED  
COMPOSITE  
UTILITY POLE  
TECHNOLOGY**



Creative Pultrusions, Inc., (CPI) is the world leader in pultrusion manufacturing. Our commitment to continuous process and product improvement has transformed CPI into a world-renowned pultruder specializing in custom profiles while utilizing high-performance resins and our proprietary high-pressure injection process.

As one of the world's most innovative leaders in the fiber reinforced polymer (FRP) composites industry, we have partnered with Powertrusion International, Inc. to provide composite utility poles that are prefabricated and designed to provide lasting performance in harsh environments.

## ELECTRICAL DISTRIBUTION & TRANSMISSION POLES

At CPI, our composite utility poles have been engineered to outperform wood, steel, and concrete poles and to stand the test of time.

The composite utility poles have been vetted for approximately two decades by many utility companies positioned around the globe.

Utilities specify and install our composite utility poles for their inherent properties including:

- Light Weight
- Corrosion and Rot Resistance
- Superior Dielectric Strength
- Unaffected by Woodpeckers and Termites
- Environmentally Safe, Will Not Leach
- No Pesticides or Preservatives
- Lineman Safety
- Community Safety
- High Reliability

## WHAT IS PULTRUSION?

Pultrusion is a continuous manufacturing process utilized to make composite profiles with constant cross-sections whereby fiberglass reinforcements, in the form of roving and mats, are saturated with resin and channelled into a heated die. The profile exits the die in a solid state and in the form of the desired cross-section.

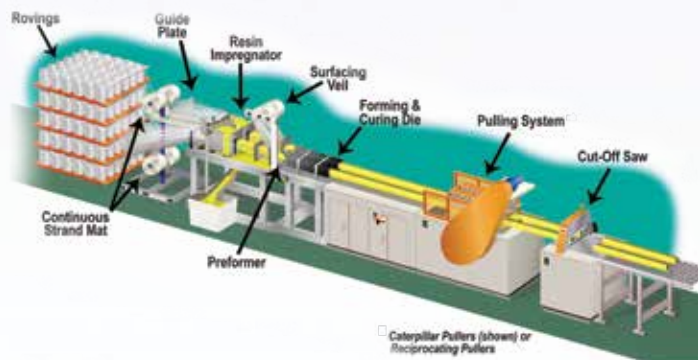

## POLE CONSTRUCTION

Composite utility poles have been engineered to meet American National Standard Institute (ANSI) and National Electric Safety Code (NESC) code requirements. The poles are pultruded with advanced UV protection in a matrix that offers superior toughness and strength. In addition, the poles exhibit excellent corrosion, moisture and fire resistance properties.

The top cap and bottom plug are designed to stand the test of time while mitigating rodent and bird intrusion into the pole. The bottom plug permits water to ingress and egress as the water table fluctuates and provides a solid foundation for the pole.

Bolt Pull Through Testing



### 1. ADVANCED UV PROTECTION

CPI's composite utility poles contain three layers of UV protection. First, CPI adds light stabilizers to each pole. The light stabilizers are mixed into the thermoset resin, prior to production, and function as long term thermal and light stability promoters. Second, the composite utility poles are encompassed with a 10 mil polyester surfacing veil. The 10 mil veil creates a resin rich surface and protects the glass reinforcements from fiber blooming. Third, the poles are UV protected with an aliphatic polyurethane surface finish.

### 2. RESIN/MATRIX

The FRP poles are manufactured with a high performance thermoset resin system exhibiting superior toughness and strength. Thermoset resins, once cured, are very structural and stable and are highly resistance to moisture and harsh environments.

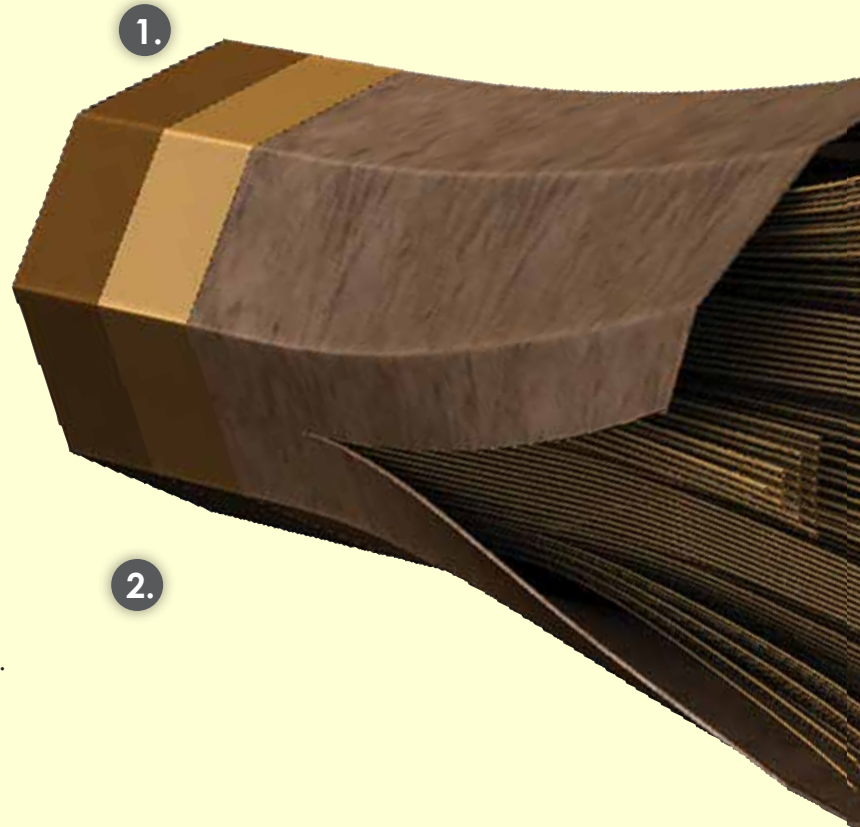

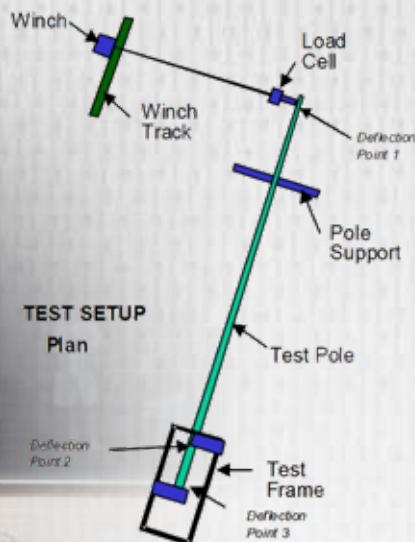

Guy Testing



## POLE TESTING

The composite utility poles are tested both in house and at EDM International (EDM), Fort Collins, Colorado, in accordance with the principles set forth in the ASTM D1036 test procedure. Poles are tested in a horizontal cantilever arrangement with the butt-end placed inside a rigid test frame and held in position by 12-inch wide nylon slings. The load cable is attached approximately two feet from the pole tip using a nylon strap. The load is applied at a constant rate of deformation using a winch. The winch is mounted on a trolley that moves along a track to keep the load perpendicular to the original pole axis. CPI's and EDM's test facilities are equipped with a pole holding fixture, loading system, electronic load deflection measuring sensors, and a computerized data acquisition system.

In addition to full section pole testing, other tests have been conducted to evaluate the pin bearing, washer pull through, and guy attachment strength. The capacities have been published based on a 5% Lower Exclusion Limit (LEL).

## 3. FIBERGLASS REINFORCEMENTS

3.

All composite utility poles are manufactured with electrical grade E-glass reinforcements in the form of unidirectional roving, Continuous Filament Mat (CFM) and stitched fabric mats. All E-glass reinforcements meet a minimum tensile strength of 290 ksi per ASTM D2343.

## 4. TOP CAPS AND BASE PLUGS

The top caps and base plugs have been engineered to prevent rodent and insect infestation into the pole. The Low Density Polyethylene (LDP) and FRP caps and plugs are custom molded to snugly fit the poles. The base plug provides foundation support to keep the hollow pole from shearing into the soil.

4.

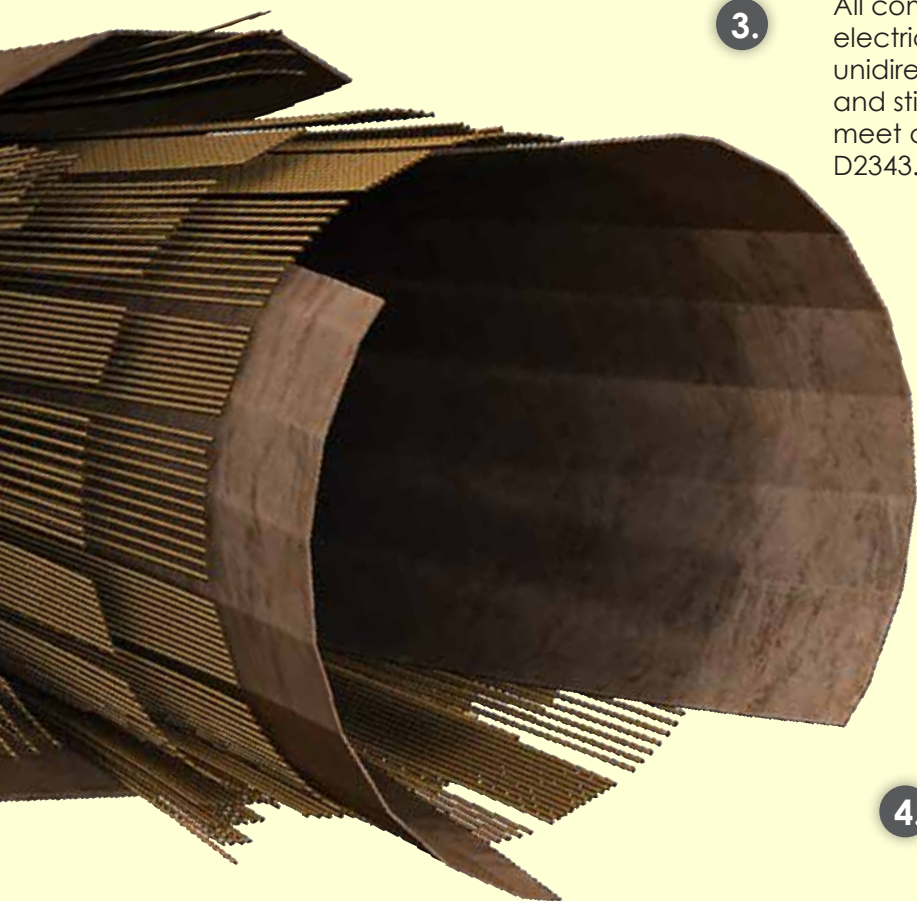

## WHY SHOULD YOU BUY CPI COMPOSITE UTILITY POLES

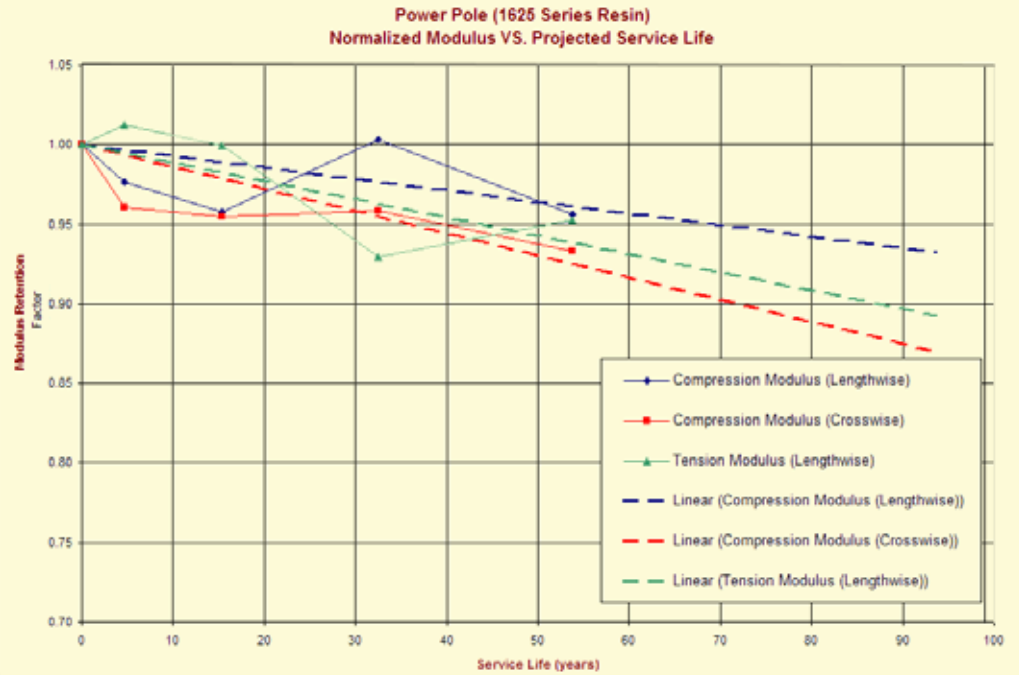

### SAFETY

High dielectric strength enhances lineman and ground hand safety during live line pole replacement sets. Mitigate safety concerns with composite utility poles.



### NO DANGEROUS PESTICIDES OR CHEMICALS

Unlike treated wood poles, composite utility poles contain no dangerous pesticides or chemicals that will leach into the environment or cause occupational hazards. Ideal for school yard, downtown, highly occupied areas, and watershed applications.



### FIRE RETARDANT

Composite utility poles are manufactured with fire retardant additives for optimal performance in the event of a brush or pole top fire. Specifically, the poles will pass UL94 (VO), ASTM E84 Class A, and ASTM D635 - "Self Extinguishing".



## ENGINEERED POLE

Composite utility poles are an engineered product. The engineered pole is manufactured in a production plant and exhibits a coefficient of variation of less than 5%. You get a stronger pole that will maintain its design strength over an extended period of time.



## UNAFFECTED BY TERMITES, WOODPECKERS AND VERMIN

Composite utility poles are unaffected by termites, woodpeckers and vermin, reducing future installation costs.



## WILL NOT ROT

Composite utility poles will not rot, spall or corrode due to the environment. Wood pole strengths have been known to decrease 80% in a few years when exposed to harsh environments.



## LIGHTWEIGHT

Ideal for limited access areas and helicopter sets.



## COLOR

The distribution and transmission poles come standard in a Brown Gray color, RAL7013. Light Gray, Brown RAL8014 and custom colors are available upon request. Consult your Outside Sales Representative or Inside Account Manager for details.

# MECHANICAL & PHYSICAL PROPERTIES

## OCTAGONAL POLES

Mechanical Properties	Octagonal Pole 8" x .25" Series II CP076 (203mm x 6.35mm)	Octagonal Pole 10"x.25"Series II CP074 (254mm x 6.35mm)	Octagonal Pole 10" x.275" Series III CP210 (254mm x 6.98)
Flexural Strength per ASTM D1036 psi (Mpa) <sup>3</sup>	46,999 (324)	41,374 (285)	42,076 (290)
Compression Strength per ASTM D1036 psi (Mpa) <sup>3</sup>	46,999 (324)	41,374 (285)	42,076 (290)
Axial Compression Strength psi (Mpa) <sup>3</sup>	46,999 (324)	41,374 (285)	42,076 (290)
Ultimate Axial Compression Capacity (Short Column) lbf (kg) <sup>3</sup>	362,832 (164,578)	445,184 (201,932)	566,763 (257,079)
Modulus of Elasticity psi (Gpa)	4.30E6 (29.6)	4.00E6 (27.5)	3.70E6 (25.5)
Bending Stiffness (EI) per ASTM D1036 lb•in <sup>2</sup> (kg•mm <sup>2</sup> )	2.62E8 (7.65E10)	5.58E8 (1.63E11)	6.35E8 (1.86E11)
Ultimate Moment Capacity per ASTM D1036 lb•ft (kN•m) <sup>3</sup>	59,611 (80.8)	94,437 (128)	117,953 (160)
Max. Bolt Torque lb•ft (N•m) <sup>1</sup>	50 (67.8)	50 (67.8)	50 (67.8)
Ultimate Pole Torque Strength lb•ft (N•m)	22,712 (30,793)	34,413 (46,658)	41,797 (56,669)
Ultimate Pin Bearing Strength Lengthwise psi (Mpa) <sup>2,3</sup>	20,110 (138)	23,348 (161)	15,598 (107)
Ultimate Pin Bearing Strength Crosswise psi (Mpa) <sup>2,3</sup>	10,283 (71)	7,458 (51)	7,123 (49)
Ultimate Washer Pull Through Strength kip (kg) (using a 4"x3/8" square washer <sup>3</sup> )	11.8 (5,346)	13 (5,903)	12.8 (5,807)
Ultimate Shear Capacity, Calculated (lb) (kN) <sup>3</sup>	35,166 (156)	42,354 (188)	51,563 (229)
In-Plane Shear Strength per ASTM D5379 psi (Mpa) <sup>3</sup>	11,555 (79.7)	11,062 (76.3)	12,277 (84.6)
Physical Properties			
Moment of Inertia in <sup>4</sup> (mm <sup>4</sup> )	60.87 (2.53E7)	139.69 (5.81E7)	171.57 (7.14E7)
Section Modulus in <sup>3</sup> (mm <sup>3</sup> )	15.22 (2.49E5)	27.39 (4.49E5)	33.64 (5.51E5)
Radius of Gyration in (mm)	2.81 (71.4)	3.60 (91.4)	3.57 (90.7)
Weight lb/ft (N/m)	6.33 (92.4)	8.82 (128.7)	11.05 (161.3)
Wall Thickness in (mm)	0.25 (6.35)	0.25 (6.35)	0.275 (6.98)
Coefficient of Thermal Expansion (CTE) Lengthwise in/ in/°F	5.00E-06	5.00E-06	5.00E-06
Water Absorption ASTM D570 (max)	0.60% (24hrs)	0.60% (24hrs)	0.60% (24hrs)
Fiber Volume Fraction %	≥50%	≥50%	≥50%
Cross Sectional Area in <sup>2</sup> (mm <sup>2</sup> )	7.72 (4980)	10.76 (6942)	13.47 (8690)
Surface Area ft <sup>2</sup> /ft (m <sup>2</sup> /m)	2.2 (.67)	2.8 (.85)	2.8 (.85)
Fire Properties			
Flame Rating (UL 94)	V0 Self Extinguishing	V0 Self Extinguishing	V0 Self Extinguishing
Flame Spread ASTM E-84	Class A 25 or less	Class A 25 or less	Class A 25 or less
Flame Rating ASTM D635	Self Extinguishing	Self Extinguishing	Self Extinguishing
Electrical Properties			
ASTM F711 (100 kVAC per foot - 5 minutes dry)	Passed	Passed	Passed
IEEE978 (75 kVAC per foot - 1 minute wet)	Passed	Passed	Passed

### Notes:

1. Max torque based on utilizing 4"x4"x3/8" steel washers.
2. Capacity based on testing conducted with 3/4" hardware.
3. Values have been factored based on a 5% Lower Exclusion Limit (LEL) per NESC 2007 requirements.  
(LW) - Lengthwise  
(PF) - Perpendicular to Face

# MECHANICAL & PHYSICAL PROPERTIES

## ROUND POLES

Mechanical Properties	Round Pultruded Pole TU440 Polyester 10"x3/8" (254mm x 9.52mm)	Round Pultruded Pole TU455 12"x3/8" (305mm x 9.5mm)	Round Pultruded Pole TU450 12"x1/2" (305mm x 12.7mm)	Round Pultruded Pole TU460 16"x1/2" (406mm x 12.7mm)
Flexural Strength per ASTM D1036 psi (Mpa) <sup>3</sup>	59,585 (411)	51,790 (357)	58,825 (406)	50,984 (351)
Compression Strength per ASTM D1036 psi (Mpa) <sup>3</sup>	59,585 (411)	51,790 (357)	58,825 (406)	50,984 (351)
Axial Compression Strength psi (Mpa) <sup>3</sup>	59,585 (411)	51,790 (357)	58,825 (406)	50,984 (351)
Ultimate Axial Compression Capacity (Short Column) lbf (kg) <sup>3</sup>	675,634 (306,463)	709,523 (321,834)	1,064,732 (482,954)	1,238,911 (561,960)
Modulus of Elasticity per ASTM D1036 psi (Gpa)	6.31E6 (43.5) <sup>5</sup>	5.10E6 (35.2) <sup>4</sup>	5.84E6 (40.3)	5.52E6 (38.1)
Bending Stiffness (EI) per ASTM D1036 lb•in <sup>2</sup> (kg•mm <sup>2</sup> )	8.30E8 (243E9) <sup>5</sup>	1.18E9 (345E9) <sup>4</sup>	1.75E9 (512E9)	4.04E9 (118E10)
Ultimate Moment Capacity per ASTM D1036 lb•ft (kN•m) <sup>3</sup>	130,590 (177)	166,591 (226)	244,124 (331)	388,752 (526)
Max. Bolt Torque lb•ft (N•m) <sup>1</sup>	50 (67.8)	50 (67.8)	50 (67.8)	50 (67.8)
Ultimate Pole Torque Strength lb•ft (N•m)	49,076 (66,538)	81,468 (110,456)	82,662 (112,075)	185,342 (251,290)
Ultimate Pin Bearing Strength Lengthwise psi (Mpa) <sup>2,3</sup>	27,755 (191.4)	20,553 (142)	24,585 (169.5)	20,087 (138.5)
Ultimate Pin Bearing Strength Crosswise psi (Mpa) <sup>2,3</sup>	16,577 (114.3)	13,412 (92.5)	14,063 (97.0)	12,399 (85.5)
Ultimate Washer Pull Through Strength kip (kg) <sup>3,6</sup>	14.8 (6,719)	15.5 (7,043)	18.9 (8,593)	20.2 (9,162)
Ultimate Shear Capacity, Calculated (lb) (kN) <sup>3</sup>	53,611 (238)	84,125 (374)	86,428 (384)	143,212 (637)
In-Plane Shear Strength per ASTM D5379 psi (Mpa) <sup>3</sup>	9,456 (65.2)	12,281 (84.7)	9,550 (65.8)	11,787 (81.3)
<b>Physical Properties</b>				
Moment of Inertia in <sup>4</sup> (mm <sup>4</sup> )	132 (5.47E7)	231 (9.61E7)	299 (1.24E8)	732 (3.04E8)
Section Modulus in <sup>3</sup> (mm <sup>3</sup> )	26.3 (4.31E5)	38.6 (6.32E5)	49.8 (8.16E5)	91.5 (1.50E6)
Radius of Gyration in (mm)	3.41 (86.6)	4.11 (104.4)	4.07 (103.4)	5.48 (139.2)
Weight lb /ft (N/m)	10.3 (150.3)	12 (175)	15.6 (227.7)	21.0 (306.5)
Wall Thickness in (mm)	0.375 (9.52)	0.375 (9.52)	0.5 (12.7)	0.5 (12.7)
Coefficient of Thermal Expansion (CTE) Lengthwise in/in/°F	5.00E-6	5.00E-6	5.00E-6	5.00E-6
Water Absorption ASTM D570 (max)	2.0% (24 hrs)	0.60% (24hrs)	0.60% (24hrs)	0.60% (24hrs)
Fiber Volume Fraction %	≥50%	≥50%	≥50%	≥50%
Cross Sectional Area in <sup>2</sup> (mm <sup>2</sup> )	11.3 (7,290)	13.7 (8,839)	18.1 (11,700)	24.3 (15,700)
Surface Area ft <sup>2</sup> /ft (m <sup>2</sup> /m)	2.6 (0.80)	3.1 (0.96)	3.1 (0.96)	4.2 (1.28)
<b>Fire Properties</b>				
Flame Rating (UL 94)	V0 Self Extinguishing	V0 Self Extinguishing	V0 Self Extinguishing	V0 Self Extinguishing
Flame Spread ASTM E-84	Class A 25 or less	Class A 25 or less	Class A 25 or less	Class A 25 or less
<b>Electrical Properties</b>				
ASTM F711 (100 kVAC per foot - 5 minutes dry)	Passed	Passed	Passed	Passed
IEEE978 (75 kVAC per foot - 1 minute wet)	Passed	Passed	Passed	Passed

### Notes:

1. Max torque based on utilizing 6"x1/2" steel washers.
  2. Capacity based on testing conducted with 3/4" hardware for the TU440 and 1" hardware for all others.
  3. Values have been factored based on a 5% Lower Exclusion Limit (LEL) per NESC 2007 requirements.
  4. Modulus of elasticity value obtained from ASTM D6109 protocol.
  5. Modulus of elasticity value obtained from ASTM D638 protocol.
  6. Capacity based on testing conducted with 6"x3/8" square/radius washer for the TU440 and 6"x1/2" square/radius washer for all others.
- (LW) - Lengthwise  
(PF) - Perpendicular to Face

# OCTAGONAL POLE LOAD CHARTS

## Octagonal Pole Chart Selection Guide Based on the 2007 NESC 5% LEL Requirements

Pole Strength Classification	Pole Length: FT		30	35
	Moment Length: FT		22.5	27.0
	POLE CLASS	Tip Load: lbs	Moment lb-ft	Moment lb-ft
ANSI O5.1 / GO95	5	1900	42750	51300
Wood Pole with NESC .85 Strength Reduction Factor (Grade C)	5	1615	36338	43605
Wood Pole with NESC .65 Strength Reduction Factor (Grade B)	5	1235	27788	33345
ANSI O5.1 / GO95	4	2400	54000	64800
Wood Pole with NESC .85 Strength Reduction Factor (Grade C)	4	2040	45900	55080
Wood Pole with NESC .65 Strength Reduction Factor (Grade B)	4	1560	35100	42120
ANSI O5.1 / GO95	3	3000	67500	81000
Wood Pole with NESC .85 Strength Reduction Factor (Grade C)	3	2550	57375	68850
Wood Pole with NESC .65 Strength Reduction Factor (Grade B)	3	1950	43875	52650
ANSI O5.1 / GO95	2	3700	83250	99900
Wood Pole with NESC .85 Strength Reduction Factor (Grade C)	2	3145	70763	84915
Wood Pole with NESC .65 Strength Reduction Factor (Grade B)	2	2405	54113	64935
ANSI O5.1 / GO95	1	4500	101250	121500
Wood Pole with NESC .85 Strength Reduction Factor (Grade C)	1	3825	86063	103275
Wood Pole with NESC .65 Strength Reduction Factor (Grade B)	1	2925	65813	78975
Octagonal Pole Section	X-sectional Area (in <sup>2</sup> )	Average Ultimate Moment Capacity (lb-ft)	NESC 5% LEL Moment Capacity	Weight lbs/ft of pole
8" x .25" Octagonal Pole Series II CP076	7.72	62,368	59,611	6.33
Pole Tip Deflection (inches) per Every 500 lbs Applied at Pole Tip			17	28
10" x .25" Octagonal Pole Series II CP074	10.76	100,047	94,437	8.82
Pole Tip Deflection (inches) per Every 500 lbs Applied at Pole Tip			8	13
10" x .275" Octagonal Pole Series III CP210	13.47	123,048	117,953	11.05
Pole Tip Deflection (inches) per Every 500 lbs Applied at Pole Tip			7	12
Refer to the Round Pole Selection Chart <sup>4</sup>				

### Notes:

- 1.0 Charts are based on pole tip load/bending strength. Serviceability may control pole selection.
- 2.0 The obsolete 10 in. Series IV Pole can be replaced with a round TU455 pole. Reference Round Pole Chart.
- 3.0 The ANSI O5.1/GO95 row is compared against the average ultimate strength of an FRP pole.
- 4.0 Larger round poles can be selected for the poles identified in the white boxes.

The Octagonal and Round Pole Load Charts are based upon ANSI O5.1 and General Order 95 wood pole class strength requirements. The pole classes range from 1 to 5 (Octagonal Pole) and 4 to H3 (Round Pole), with H3 being more stringent. The poles are classified by the class number. The class number is based upon the strength rating of the pole in terms of the ultimate tip load that will cause the pole to fail. The tip location is defined as a location two feet below the top of the pole. The pole is considered to be buried in the ground at a level that represents 10% of the pole length plus an additional 2 ft. The ultimate moment capacity is based upon the moment arm length and the tip load. For example, a 45' pole has an effective moment arm of 36.5' derived as  $45' - [(45 \times 10\%) + 2' + 2'] = 36.5'$ .

The FRP poles have been classed the same as wood for simplicity. However, FRP poles are much more reliable than wood poles and should be selected based on reliability. The FRP poles are an engineered product and when tested exhibit a low coefficient of variation, less than 5%. Wood poles exhibit a coefficient of variation of 20%. Fiberglass poles and crossarms have been added to the

NESC as having the same reliability as steel and prestressed-concrete poles. The resulting strength factor is one as described in Table 261-1 of the NESC. Wood requires a strength factor of .65 and .85 for grade B and C construction respectively. What does this mean to the Utility Engineer? An FRP pole with lower pole class strengths can be selected that will have the same reliability or better than a wood pole. In order to directly compare wood poles to FRP poles the NESC code should be utilized and the coefficient of variations between the wood and FRP poles should be considered.

The Octagonal and Round Pole Load Charts contain three lines per Pole Class within the Pole Strength Classification column. The top line contains the tip load and class requirement when comparing an average strength FRP pole directly to an average strength wood pole without any consideration to reliability. The second and third lines consider the wood pole tip load requirements with a .85 and .65 strength reduction factor respectively. The equivalent FRP pole capacities for lines two and three, within each pole class, have been published based on 5% LEL values. According to the NESC code, the FRP pole should be selected based on

	40	45	50	55	60
	32.0	36.5	41.0	45.5	50.0
	Moment lb-ft	Moment lb-ft	Moment lb-ft	Moment lb-ft	Moment lb-ft
	60800	69350	77900	86450	95000
	51680	58948	66215	73483	80750
	39520	45078	50635	56193	61750
	76800	87600	98400	109200	120000
	65280	74460	83640	92820	102000
	49920	56940	63960	70980	78000
	96000	109500	123000	136500	150000
	81600	93075	104550	116025	127500
	62400	71175	79950	88725	97500
	118400	135050	151700	168350	185000
	100640	114793	128945	143098	157250
	76960	87783	98605	109428	120250
	144000	164250	184500	204750	225000
	122400	139613	156825	174038	191250
	93600	106763	119925	133088	146250
	Moment of Inertia (in <sup>4</sup> )	Section Modulus (in <sup>3</sup> )	Radius of Gyration (in)	Modulus of Elasticity (psi)	5% LEL Bending Stress at Failure (psi)
	60.87	15.22	2.81	4.30E+06	46,999
	43	63			
	139.69	27.39	3.60	4.00E+06	41,374
	20	29	41	55	72
	171.57	33.64	3.57	3.70E+06	42,076
	18	26	36	49	64

the classification of construction grade. For example, a Class Three FRP to wood equivalent pole for grade B construction only needs a tip capacity of 1,950 lbs to have the same reliability as a class three wood pole which requires a tip capacity of 3,000 lbs.

In the event you do not know your grade of construction, the grade C reduction factor of .85 should be applied to wood pole strength requirement in order to economically select a FRP pole.

The columns within the spreadsheet are set up based on various pole lengths. The proper FRP pole should be selected based on the color and the moment described in each cell. The pole selected should have a pole class moment lower than the 5% LEL moment published in the Octagonal Pole Section Table located at the bottom of the chart. The section properties, moment capacities and 5% LEL bending strengths have been noted at the bottom of the chart. If additional information is required, please reference the Mechanical & Physical Properties Octagonal Poles chart on Page 6 or the Mechanical & Physical Properties Round Poles chart on Page 7.

Please note that serviceability and or connection capacities may dictate the appropriate pole selection.



## ROUND POLE LOAD CHARTS

Round Pole Chart Selection Guide Based on the 2007 NESC 5% LEL Requirements					
Pole Strength Classification	Pole Length: FT		30	35	40
	Moment Length: FT		22.5	27.0	32.0
	POLE CLASS	Tip Load: lbs	Moment lb-ft	Moment lb-ft	Moment lb-ft
ANSI O5.1 / GO95	4	2400	54000	64800	76800
Wood Pole with NESC .85 Strength Reduction Factor (Grade C)	4	2040	45900	55080	65280
Wood Pole with NESC .65 Strength Reduction Factor (Grade B)	4	1560	35100	42120	49920
ANSI O5.1 / GO95	3	3000	67500	81000	96000
Wood Pole with NESC .85 Strength Reduction Factor (Grade C)	3	2550	57375	68850	81600
Wood Pole with NESC .65 Strength Reduction Factor (Grade B)	3	1950	43875	52650	62400
ANSI O5.1 / GO95	2	3700	83250	99900	118400
Wood Pole with NESC .85 Strength Reduction Factor (Grade C)	2	3145	70763	84915	100640
Wood Pole with NESC .65 Strength Reduction Factor (Grade B)	2	2405	54113	64935	76960
ANSI O5.1 / GO95	1	4500	101250	121500	144000
Wood Pole with NESC .85 Strength Reduction Factor (Grade C)	1	3825	86063	103275	122400
Wood Pole with NESC .65 Strength Reduction Factor (Grade B)	1	2925	65813	78975	93600
ANSI O5.1 / GO95	H1	5400	121500	145800	172800
Wood Pole with NESC .85 Strength Reduction Factor (Grade C)	H1	4590	103275	123930	146880
Wood Pole with NESC .65 Strength Reduction Factor (Grade B)	H1	3510	78975	94770	112320
ANSI O5.1 / GO95	H2	6400	144000	172800	204800
Wood Pole with NESC .85 Strength Reduction Factor (Grade C)	H2	5440	122400	146880	174080
Wood Pole with NESC .65 Strength Reduction Factor (Grade B)	H2	4160	93600	112320	133120
ANSI O5.1 / GO95	H3	7500	168750	202500	240000
Wood Pole with NESC .85 Strength Reduction Factor (Grade C)	H3	6375	143438	172125	204000
Wood Pole with NESC .65 Strength Reduction Factor (Grade B)	H3	4875	109688	131625	156000
Round Pole Section		X-sectional Area (in <sup>2</sup> )	Average Ultimate Moment Capacity (lb-ft)	NESC 5% LEL Moment Capacity	Weight lbs/ft of pole
10 in Dia. x 3/8" Round Pole TU440		11.3	144,041	130,590	10.3
Pole Tip Deflection (inches) per Every 1000 lbs Applied at Pole Tip			11	18	27
12 in Dia. x 3/8" Round Pole TU455		13.7	178,909	166,593	12.0
Pole Tip Deflection (inches) per Every 1000 lbs Applied at Pole Tip			8	13	19
12 in Dia. x 1/2" Round Pole TU450		18.1	262,009	244,124	15.6
Pole Tip Deflection (inches) per Every 1000 lbs Applied at Pole Tip			5	8	13
16 in Dia. x 1/2" Round Pole TU460		24.3	400,368	388,752	21.0
Pole Tip Deflection (inches) per Every 1000 lbs Applied at Pole Tip			2	4	6
Refer to the Octagonal Pole Selection Chart <sup>3</sup>					

### Notes:

- 1.0 Charts are based on pole tip load/bending strength. Serviceability may control pole selection.
- 2.0 The ANSI O5.1/GO95 row is compared against the average ultimate strength of an FRP pole.
- 3.0 Smaller Octagonal poles can be selected for the poles identified in the white boxes

	45	50	55	60	65	70	75	80
	36.5	41.0	45.5	50.0	54.5	59.0	63.5	68
	Moment lb-ft	Moment lb-ft	Moment lb-ft	Moment lb-ft	Moment lb-ft	Moment lb-ft	Moment lb-ft	Moment lb-ft
	87600	98400	109200	120000	130800	141600	152400	163200
	74460	83640	92820	102000	111180	120360	129540	138720
	56940	63960	70980	78000	85020	92040	99060	106080
	109500	123000	136500	150000	163500	177000	190500	204000
	93075	104550	116025	127500	138975	150450	161925	173400
	71175	79950	88725	97500	106275	115050	123825	132600
	135050	151700	168350	185000	201650	218300	234950	251600
	114793	128945	143098	157250	171403	185555	199708	213860
	87783	98605	109428	120250	131073	141895	152718	163540
	164250	184500	204750	225000	245250	265500	285750	306000
	139613	156825	174038	191250	208463	225675	242888	260100
	106763	119925	133088	146250	159413	172575	185738	198900
	197100	221400	245700	270000	294300	318600	342900	367200
	167535	188190	208845	229500	250155	270810	291465	312120
	128115	143910	159705	175500	191295	207090	222885	238680
	233600	262400	291200	320000	348800	377600		
	198560	223040	247520	272000	296480	320960	345440	369920
	151840	170560	189280	208000	226720	245440	264160	282880
	273750	307500	341250	375000				
	232688	261375	290063	318750	347438	376125		
	177938	199875	221813	243750	265688	287625	309563	331500
	<b>Moment of Inertia (in<sup>4</sup>)</b>	<b>Section Modulus (in<sup>3</sup>)</b>	<b>Radius of Gyration (in)</b>	<b>Modulus of Elasticity (psi)</b>	<b>5% LEL Bending Stress at Failure (psi)</b>			
	132	26.3	3.41	6.31E+06	59,585			
	39	55	74	97	125	157	194	237
	231	38.6	4.11	5.10E+06	51,790			
	28	39	52	69	88	111	137	168
	299	49.8	4.07	5.84E+06	58,825			
	19	26	35	46	59	75	93	113
	732	91.5	5.48	5.52E+06	50,984			
	8	11	15	20	26	32	40	49

## GUYING FRP POLES

The guy capacity of both the octagonal and round FRP poles is dictated by the pin bearing strength of the FRP material, the wall thickness, and the diameter of the bolt(s) being utilized in the connection.

The Utility Engineer is encouraged to use the pole guy charts below for both the octagonal and round poles for determining the optimal pole guy connection for the guy load scenario.

The charts are set up for guy loads ranging from 5,000 lb to 15,000 lb per connection. The guy angle is an important consideration that influences the diameter and number of connectors required for the connection. In the event that a particular guy scenario does not fit the chart parameters. A custom design can be detailed based on the pin bearing strengths dictated in the mechanical and physical property sheets and by following the recommended edge distances spelled out in the Bolted Connections section on Page 14.

### OCTAGONAL POLE GUY CHARTS

Guy Load per attachment (lbs)	Guy Angle Ø	Guy attachment vertical component load (lbs)	8"x.25" Series II CP076		10"x.25" Series II CP074		10"x.275" Series III CP0210	
			Number of 5/8" bolts required in attachment	Number of 3/4" bolts required in attachment	Number of 5/8" bolts required in attachment	Number of 3/4" bolts required in attachment	Number of 5/8" bolts required in attachment	Number of 3/4" bolts required in attachment
5,000	15	4,830	1.5	1.3	1.3	1.1	1.8	1.1
5,000	30	4,330	1.4	1.1	1.2	1.0	1.6	1.0
5,000	45	3,536	1.1	0.9	1.0	0.8	1.3	0.8
7,500	15	7,244	2.3	1.9	2.0	1.7	2.7	1.7
7,500	30	6,495	2.1	1.7	1.8	1.5	2.4	1.5
7,500	45	5,303	1.7	1.4	1.5	1.2	2.0	1.2
10,000	15	9,659	3.1	2.6	2.6	2.2	3.6	2.2
10,000	30	8,660	2.8	2.3	2.4	2.0	3.2	2.0
10,000	45	7,071	2.3	1.9	1.9	1.6	2.6	1.6
15,000	15	14,489	4.6	3.8	4.0	3.3	5.4	3.3
15,000	30	12,990	4.1	3.4	3.6	3.0	4.8	3.0
15,000	45	10,607	3.4	2.8	2.9	4.8	4.0	4.8

### ROUND POLE GUY CHARTS

Guy Load per attachment (lbs)	Guy Angle Ø	Guy attachment vertical component load (lbs)	10 in Dia. x 3/8" Round Pole TU440		12 in Dia. x 3/8" Round Pole TU455		12 in Dia. x 1/2" Round Pole TU450		16 in Dia. x 1/2" Round Pole TU460	
			Number of 5/8" bolts required in attachment	Number of 3/4" bolts required in attachment	Number of 5/8" bolts required in attachment	Number of 3/4" bolts required in attachment	Number of 5/8" bolts required in attachment	Number of 3/4" bolts required in attachment	Number of 5/8" bolts required in attachment	Number of 3/4" bolts required in attachment
5,000	15	4,830	0.7	0.6	1.0	0.8	0.6	0.5	0.8	0.6
5,000	30	4,330	0.7	0.6	0.9	0.7	0.6	0.5	0.7	0.6
5,000	45	3,536	0.5	0.5	0.7	0.6	0.5	0.4	0.6	0.5
7,500	15	7,244	1.1	0.9	1.5	1.3	0.9	0.8	1.1	0.9
7,500	30	6,495	1.0	0.8	1.3	1.1	0.8	0.7	1.0	0.8
7,500	45	5,303	0.8	0.7	1.1	0.9	0.7	0.6	0.8	0.7
10,000	15	9,659	1.5	1.2	2.0	1.7	1.3	1.0	1.5	1.3
10,000	30	8,660	1.3	1.1	1.8	1.5	1.1	0.9	1.3	1.1
10,000	45	7,071	1.1	0.9	1.5	1.2	0.9	0.8	1.1	0.9
15,000	15	14,489	2.2	1.9	3.0	2.5	1.9	1.6	2.3	1.9
15,000	30	12,990	2.0	1.7	2.7	2.2	1.7	1.4	2.0	1.7
15,000	45	10,607	1.6	1.4	2.2	1.8	1.4	1.2	1.7	1.4

Notes: Chart depicts the minimum number of bolts required in the guy attachment. Appropriate safety factors shall be applied by increasing the numbers of bolts in the connection or by adding additional guy attachments to the pole.



## TYPICAL GUY ATTACHMENT DETAILS



Round Pole - TU460 16" dia.\*

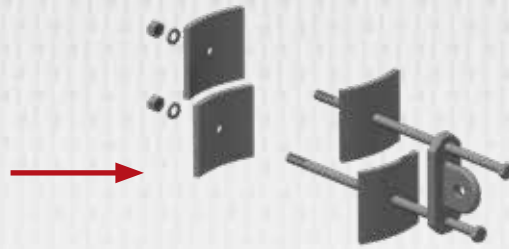

### Two Bolt Guy Attachment BOM:

- (1) FAB495 - Dead End Tee
- (2) 20" x 3/4" Bolt A325 or 5 SAE Grade
- (2) FAB186 - 3/4" Nuts A325 or 5 SAE Grade
- (2) FAB187 - 3/4" Lock/Spring Washers
- (4) FAB449 - 6" x 5.75" x 1/2" Curved Washer

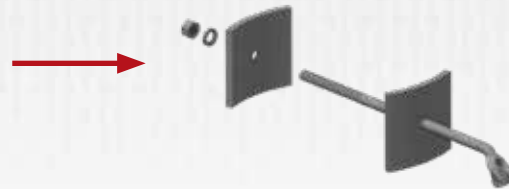

### Single Bolt Guy Attachment BOM:

- (1) Bent Thimble Bolt, 3/4" Diameter
- (1) FAB186 - 3/4" Nuts A325 or 5 SAE Grade
- (1) FAB187 - 3/4" Lock/Spring Washers
- (2) FAB449 - 6" x 5.75" x 1/2" Curved Washer

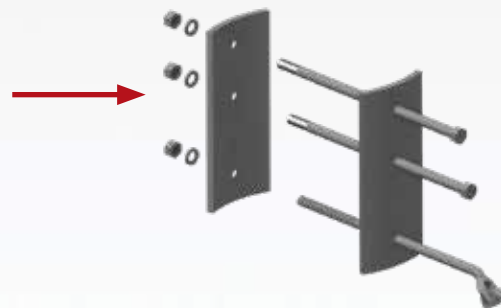

### Three Bolt Guy Attachment BOM:

- (1) Bent Thimble Bolt, 3/4" Diameter
- (2) 20" x 3/4" Bolt A325 or 5 SAE Grade
- (2) FAB461 - 16" Round Pole Guy Support Plate
- (3) FAB186 - 3/4" Nuts A325 or 5 SAE Grade
- (3) FAB187 - 3/4" Lock/Spring Washers

\*NOTE: Detail shown with round pole for clarification purposes. The same guy hardware can be used with the octagonal poles by substituting FAB195 - 4" x 4" x 3/8" Washer and FAB459 - Octagonal Pole Guy Support Plate for the FAB449 and FAB461 respectively. Hardware items can be viewed on page 21.

The octagonal and round poles can be guyed with traditional guy attachments excluding any hardware with cleats. A guy attachment must always include oversized washers. Specifically, all octagonal poles shall utilize two 4" x 4" x 3/8" galvanized steel flat washers for each single guy connection. The round poles require two 6" x 5.75" x 1/2" curved washers or single guy connection. This detail can be viewed in both the round and octagonal guy connection detail rendering.

For double bolted guy attachments in which a dead end tee is utilized for the guy connection, four square curved washers shall be utilized depending on the style of pole being specified. This connection detail can be viewed in the guy connection renderings for both the octagonal and round poles.

For heavy guy connections requiring three bolts to achieve the guy load a guy support plate shall be utilized. The guy support plates are detailed in the hardware options section of this brochure and are readily available for purchase. The main function of the guy support plate is to allow for two or three bolts to be utilized in a guy connection to increase the guy connection capacity. The guy support plates for both the octagonal and round poles can be viewed in the connection detail renderings.

## CONNECTIONS

### BOLTED CONNECTIONS

Proper bolt hole location limits are depicted in this Edge Distance Chart. This chart describes the minimum edge, gauge, pitch end and stagger distances for holes being drilled into the composite utility poles. The distances are based on a 1/16" oversized holes off of the nominal bolt diameters.

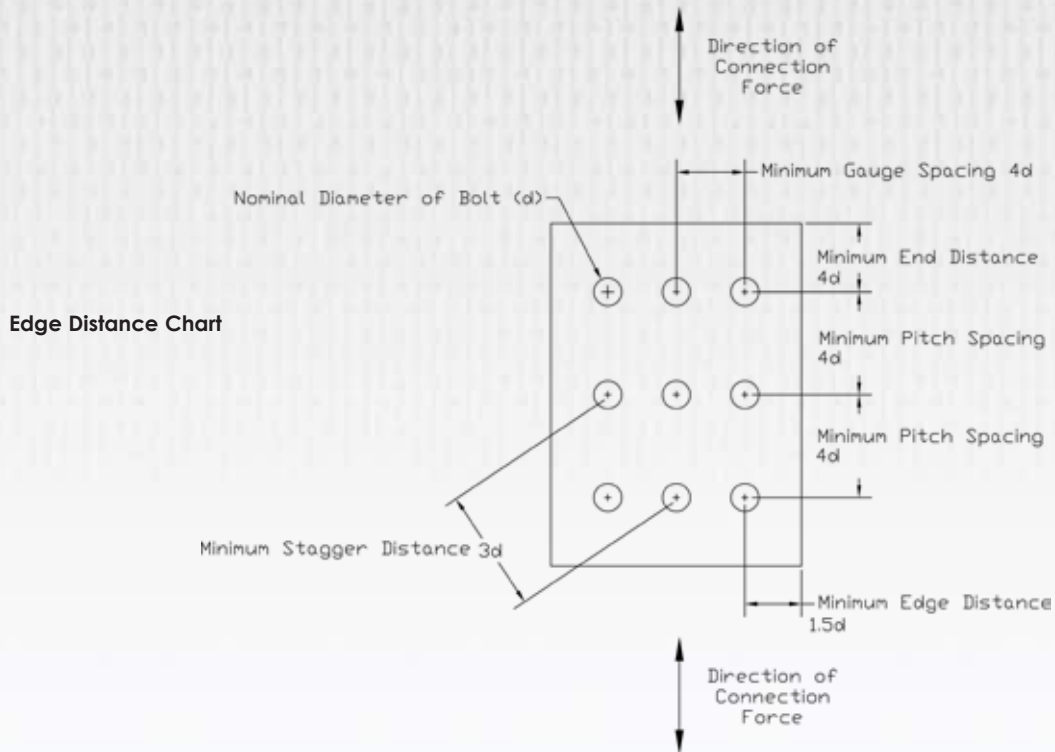

The bolted connection charts have been set up for 5/8", 3/4", and 1" diameter bolts for connections with forces acting parallel to the pole. Examples of connections exhibiting forces parallel to the pole include transformers, tangent signaling wire, tangent communication wires and tangent crossarms. The characteristic values need to have safety factors applied. Connections with forces transverse to the pole shall be designed based on the bolted connection chart referencing transverse bolt bearing strengths. Parallel connections include all loads applied no greater than  $\pm 5^\circ$  off  $0^\circ$  when  $0^\circ$  is defined as parallel to the pole. Any load transferred into the pole at an angle greater than  $\pm 5^\circ$  shall be designed in accordance with the transverse load bearing strength chart.



#### Characteristic Strength of a Bolted Connection for Forces Applied Parallel to the Pole

Octagonal Pole	Single 5/8" Bolt	Two 5/8" Bolts	Single 3/4" Bolt	Two 3/4" Bolts	Single 1" Bolt	Two 1" Bolts
8"x.25" Series II CP076 (203mm x 6.35mm)	3,142	6,284	3,771	7,541	5,028	10,055
10"x.25" Series II CP074 (254mm x 6.35mm)	3,648	7,296	4,378	8,756	5,837	11,674
10"x.275" Series III CP210 (254mm x 6.98mm)	2,681	5,362	3,217	6,434	4,289	8,579
Round Pole	Single 5/8" Bolt	Two 5/8" Bolts	Single 3/4" Bolt	Two 3/4" Bolts	Single 1" Bolt	Two 1" Bolts
TU440 10"x3/8" (305mm x 9.5mm)	6,505	13,010	7,806	15,612	10,408	20,816
TU455 12"x3/8" (305mm x 9.5mm)	4,817	9,634	5,781	11,561	7,707	15,415
TU450 12"x1/2" (305mm x 12.7mm)	7,683	15,366	9,219	18,439	12,293	24,585
TU460 16"x1/2" (406mm x 12.7mm)	6,277	12,554	7,533	15,065	10,044	20,087

**Notes:**

Clearance hole 1/16" over nominal bolt diameter.

Characteristic strength is based on the 5% LEL lengthwise pin bearing strength. (Safety Factors are required to be applied)

## CONNECTIONS

### WASHER PULL THROUGH

The washer pull through charts depict the washer pull through ultimate and factored load capacities. The washer pull through loads represent tension loads that are applied through a bolt into properly sized washers. The loads translate into punch shear and pole crush stresses. As composite utility poles are hollow and possess thin walls, connection details are critical in the design. Composite materials do not handle point loads as well as hollow steel and wood poles. The issue can easily be overcome with the selection of oversized washers. The oversized washers dissipate point loads over a larger area thus decreasing the stress levels.

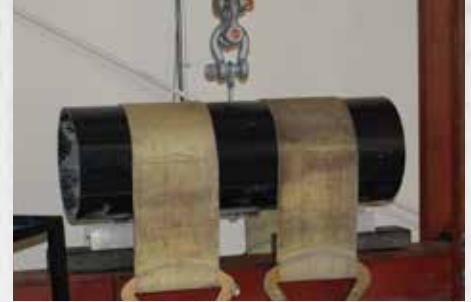

Washer Pull Through Capacity Based on a 4"x4"x3/8" Square Washer (Octagonal Pole)	5% LEL Ultimate Strength	Allowable 5% LEL Strength Based on a 3x Safety Factor
8"x.25" Series II CP076 (203mm x 6.35)	11,786	3,929
10"x.25" Series II CP074 (254mm x 6.35)	13,014	4,338
10"x.275" Series III CP210 (254mm x 6.98)	12,802	4,267
Washer Pull Through Capacity Based on a 6"x5.75"x1/2" Curved Washer (Round Pole)	5% LEL Ultimate Strength	Allowable 5% Strength based on a 3x Safety Factor
TU440 10"x3/8" (305mm x 9.5mm)	14,812	4,937
TU455 12"x3/8" (305mm x 9.5mm)	15,528	5,176
TU450 12"x1/2" (305mm x 12.7mm)	18,944	6,315
TU460 16"x1/2" (406mm x 12.7mm)	20,223	6,741

Notes:

Applied safety factor = 3

Allowable load based on 5% LEL with an applied safety factor.

TU440 based on a 6"x5.75" x3/8" square washer. All other round poles based on a 6"x5.75" x1/2" square washer.



## COLUMN LOADS

The compression capacity of the pultruded poles can be determined based on both short and long column behavior. The ultimate column load shall be determined by the lesser value of the two equations. Euler buckling governs the capacity of the long column poles.

$$F_{cr} = \sigma_c - 1/7 \frac{KL}{r}$$

Where:

- $F_{cr}$  = Critical compression stress
- $\sigma_c$  = Axial compression strength
- $K$  = Effective Length Factor
- $L$  = Laterally unbraced length of member
- $r$  = radius of gyration about the axis of buckling

$$F_{cr} = \frac{\pi^2 E}{\left(\frac{KL}{r}\right)^2}$$

Where:

- $F_{cr}$  = Critical compression stress
- $E$  = Modulus of elasticity
- $K$  = Effective Length Factor
- $L$  = Laterally unbraced length of member
- $r$  = radius of gyration about the axis of buckling

The column load charts have been set up based on the short and long column equations presented. Reference Pultex® Pultrusion Design Manual. The column load tables are based on poles that have been installed by direct burial methods. The column height is considered to be the length out of the ground to the applied compression load. The effective length factor "K" is equal to 2 based on rotation and translation free end conditions.



A pultruded column will fail in either short or long column mode. The long column capacity follows Euler buckling and is influenced by the modulus of elasticity and the radius of gyration.

The loads depicted in the column charts are unfactored ultimate load capacities. A safety factor of three is recommended.



<b>Octagonal Column Load Chart</b>							
Column Capacity Based on a K=2.0 (Rotation and Translation Free)		Ultimate Column Capacity, lbf (kgf)					
Pole Length, Above Ground, ft	Pole Length, Above Ground, m	8 in. Series II CP076		10 in. Series II CP074		10 in. Series III CP210	
22	6.71	9,280	(4,209)	19,747	(8,957)	22,487	(10,200)
24	7.31	7,797	(3,537)	16,593	(7,527)	18,896	(8,571)
26	7.92	6,644	(3,014)	14,139	(6,413)	16,100	(7,303)
28	8.53	5,729	(2,599)	12,191	(5,530)	13,883	(6,297)
30	9.14	4,990	(2,264)	10,620	(4,817)	12,093	(5,485)
32	9.75	4,386	(1,989)	9,334	(4,234)	10,629	(4,821)
34	10.36	3,885	(1,762)	8,268	(3,750)	9,415	(4,271)
36	10.97	3,466	(1,572)	7,375	(3,345)	8,398	(3,809)
38	11.58	3,110	(1,411)	6,619	(3,002)	7,537	(3,419)
40	12.19	2,807	(1,273)	5,974	(2,710)	6,802	(3,086)
42	12.80	2,546	(1,155)	5,418	(2,458)	6,170	(2,799)
44	13.41	2,320	(1,052)	4,937	(2,239)	5,622	(2,550)
46	14.02	2,123	(963)	4,517	(2,049)	5,144	(2,333)
48	14.63	1,949	(884)	4,148	(1,882)	4,724	(2,143)
50	15.24	1,797	(815)	3,823	(1,734)	4,354	(1,975)

<b>Round Column Load Chart</b>									
Column Capacity Based on a K=2.0 (Rotation and Translation Free)		Ultimate Column Capacity, lbf (kgf)							
Pole Length, Above Ground, ft	Pole Length, Above Ground, m	Round Pole TU450 10"x3/8"		Round Pole TU455 12"x3/8"		Round Pole TU450 12"x1/2"		Round Pole TU460 16"x1/2"	
36	10.97	10,962	(4,972)	15,604	(7,078)	23,150	(10,501)	53,257	(24,157)
38	11.58	9,838	(4,463)	14,005	(6,353)	20,777	(9,424)	47,799	(21,681)
40	12.19	8,879	(4,028)	12,640	(5,733)	18,752	(8,506)	43,139	(19,567)
42	12.80	8,054	(3,653)	11,464	(5,200)	17,008	(7,715)	39,128	(17,748)
44	13.41	7,338	(3,329)	10,446	(4,738)	15,497	(7,029)	35,652	(16,171)
46	14.02	6,714	(3,045)	9,557	(4,335)	14,179	(6,431)	32,619	(14,796)
48	14.63	6,166	(2,797)	8,778	(3,981)	13,022	(5,907)	29,957	(13,588)
50	15.24	5,683	(2,578)	8,089	(3,669)	12,001	(5,444)	27,609	(12,523)
52	15.85	5,254	(2,383)	7,479	(3,392)	11,096	(5,033)	25,526	(11,578)
54	16.46	4,872	(2,210)	6,935	(3,146)	10,289	(4,667)	23,670	(10,737)
56	17.07	4,530	(2,055)	6,449	(2,925)	9,567	(4,340)	22,009	(9,983)
58	17.68	4,223	(1,916)	6,012	(2,727)	8,919	(4,045)	20,518	(9,307)
60	18.29	3,946	(1,790)	5,618	(2,548)	8,334	(3,780)	19,173	(8,697)
62	18.90	3,696	(1,676)	5,261	(2,386)	7,805	(3,540)	17,956	(8,145)
64	19.51	3,468	(1,573)	4,937	(2,240)	7,325	(3,323)	16,851	(7,643)
66	20.12	3,261	(1,479)	4,643	(2,106)	6,888	(3,124)	15,845	(7,187)
68	20.73	3,072	(1,394)	4,374	(1,984)	6,488	(2,943)	14,927	(6,771)

## SERVICEABILITY AND KEY CONSIDERATIONS

### SERVICEABILITY

Composite utility poles are extremely strong. However, they exhibit a lower modulus of elasticity than steel. Therefore, serviceability limits, such as deflection, need to be scrutinized. The combination of transformer, conductor, light, telecommunications, other attachments, wind and ice all transfer moments into the pole. The combination of moments should be quantified and compared against the pole strength and deflection limitations as set fourth by the utility or applicable codes.

Deflection calculations can be conducted on the pultruded poles very simply. Specifically, the

constant cross sections enable traditional mechanics of materials equations to be utilized for predicting strength and serviceability limits. Like wood structure design, the shear modulus of elasticity should be taken into account for short pole applications if deflection is critical. For span to depth ratios above 20:1, it is common to neglect the shear portion of the total deflection and to rely solely on the flexural deflection. This simplifies the calculations while allowing for a deflection calculation which still has a high degree of certainty.



## KEY CONSIDERATIONS

The following information is being provided due to the complexity of the various design methodologies that utilities utilize around the globe.

The pultrusion industry, in combination with American Society of Civil Engineers (ASCE), has developed a standard for Load and Resistant Factor Design of Pultruded Fiber Reinforced Polymer Structures. The standard permits a reliability based design methodology to be utilized for pultruded members. In the electrical distribution and transmission industry, the NESC governs most design aspects. The NESC code heavily factors the load side of design and states that the 5% LEL values should be published for the structure material properties.

In terms of allowable stress design, for pultruded structures with sustained loads, the normal service factors applied to the pultruded pole material properties are 2.5 for flexure and compression due to bending and 3 for connections, shear and compression buckling. Once all design loads have been tabulated the engineer should verify that the sustained load recommended service factors are being met.

Pultruded utility structures exhibit strength and stiffness properties that are directional dependent. For example, the lengthwise and crosswise material properties differ due to the fact that composites are made up of mats and roving that exhibit different mechanical characteristics in lengthwise and crosswise direction. The Engineer needs to recognize this distinct difference while designing systems and setting up work instructions.

Pultruded utility structures are very structurally reliable over a long service life. However, due to the modulus of elasticity and the fact that the poles are hollow, special precaution needs to take place when designing connections and evaluating loads that are concentrated and of high magnitude. An example of such loading is bolt torque, guying and conductor termination. CPI is providing the necessary information for the Utility Engineer to comfortably put together the correct specifications and standards for a long service life. Specifying the correct hardware and making sure that the correct hardware is being utilized by the utility is crucial to the composite utility pole.



## HARDWARE OPTIONS

### OCTAGONAL POLE TOP CAPS

Top Caps are made of UV stabilized polyethylene. The top caps are pointed to discourage bird nesting and the caps are field removable in the event access to the interior of the pole is required.

Part Number	Description	Weight
FAB281	8" Top Cap (Fits CP076-8" Series II)	1 lb.
FAB283	10" Top Cap (Fits CP074-10" Series II)	1.5 lb.
FAB285	10" Top Cap (Fits CP210-10" Series III)	1.5 lb.
FAB290	1/4" x 1" Hex Head Self Tap Screw (Stainless Steel)	.013 lb.



FAB281/FAB283/FAB285

### OCTAGONAL POLE BASE PLUGS

Base Plugs are made of UV stabilized polyethylene. They are designed to resist the punching forces of the pole into the soil. They are field removable for access into the interior of the pole.

Part Number	Description	Weight
FAB282	8" Base Plug (Fits CP076-8" Series II)	1 lb.
FAB284	10" Base Plug (Fits CP074-10" Series II)	2.5 lb.
FAB286	10" Base Plug (Fits CP210-10" Series III)	2.5 lb.



FAB282/FAB284/FAB286

### ROUND POLE CAPS AND PLUGS

Pole Caps and Plugs are made of UV stabilized polyethylene or FRP flat sheet. They are designed to resist the punching forces of the pole into the soil. They are field removable for access into the interior of the pole.

Part Number	Description	Weight
FAB529.0005	Round pole cap for TU440 - 10" x 3/8" - PE	2.6 lb
FAB529.0001	Round pole cap for TU450 - 12" x 1/2" - PE	3.4 lb
FAB529.0002	Round pole cap for TU455 - 12" x 3/8" - PE	3.6 lb
FAB529.0007	Round pole cap for TU460 - 16" x 1/2" - PE	5.7 lb
FFS085.0001	Round pole cap for TU450 - 12" x 1/2" - FRP	11.1 lb.
FFS085.0007	Round pole cap for TU455 - 12" x 3/8" - FRP	11.4 lb.
FFS085.0004	Round pole cap for TU460 - 16" x 1/2" - FRP	20.4 lb.



FAB529

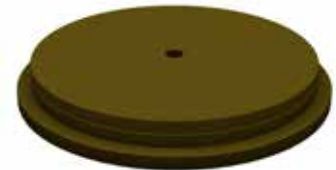

FFS085

### POLY HOLE PLUGS

Part Number	Description	Weight
FAB300	5/8" Poly Hole Plug	.1 lb.
FAB389	11/16" Poly Hole Plug	.1 lb.
FAB301	13/16" Poly Hole Plug	.1 lb.
FAB407	15/16" Poly Hole Plug	.1 lb.
FAB470	1" Poly Hole Plug	.1 lb.
FAB362	1-1/8" Poly Hole Plug	.1 lb.
FAB458	1-3/8" Poly Hole Plug	.1 lb.



FAB300/FAB389/FAB301/  
FAB407/FAB470/  
FAB362/FAB458



## HARDWARE OPTIONS

### CLIPS

Part Number	Description	Weight
PTK014	Grounding wire attachment clip. Note: use self tapping screw to secure clip to FRP arms and poles. (50 pcs./package; screw not included)	.05 lb.



PTK014

### WASHERS

Part Number	Description	Weight
FAB195	4" x 4" Square Flat Washer (3/8" thick - 13/16" hole)	1.5 lb.
FAB469	4" x 4" Curved Square Flat Washer for 12" round pole (1/4" thick - 13/16" hole)	1 lb.
FAB549	6" x 5.75" Curved Washer for 10" round pole (3/8" thick - 13/16" hole)	3.7 lb.
FAB448	6" x 5.75" Curved Washer for 12" round pole (1/2" thick - 13/16" hole)	4.8 lb.
FAB449	6" x 5.75" Curved Washer for 16" round pole (1/2" thick - 13/16" hole)	4.8 lb.
FAB459	Octagonal Pole Guy Support Plate	4.9 lb.
FAB548	10" Round Pole Guy Support Plate	9.0 lb.
FAB460	12" Round Pole Guy Support Plate	11.6 lb.
FAB461	16" Round Pole Guy Support Plate	11.6 lb.



FAB195/FAB469

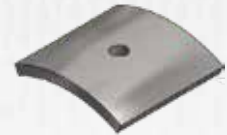

FAB549/FAB448/FAB449



FAB459



FAB548/FAB460/FAB461

**Note: Washers and plates are a structural grade steel galvanized in accordance with ASTM A123.**



## POLE STEP OPTIONS

### OCTAGONAL POLE STEP OPTIONS



FAB106



FAB287/FAB446



FAB107/FAB445



FAB288



FAB307



FAB314

Part Number	Description	Weight
FAB106	5/8"x18" Galvanized Permanent Single Sided Pole Step (Verizon Approved) Fits 10" Poles, (CP210 and CP074)	1.5 lb.
FAB107	5/8"x12" Galvanized Detachable Single Sided Step Mount, Fits 10" Poles, (CP210 and CP074) Accepts FAB307 Step	1.5 lb.
FAB287	3/4"x19" Galvanized Permanent Single Sided Climbing Pole Step, Fits 10" Poles, (CP210 and CP074)	3.5 lb.
FAB288	3/4"x24.5" Galvanized Permanent Double Sided Pole Step, Fits 10" Poles, (CP210 and CP074)	4.5 lb.
FAB307	Detachable Step, Galvanized, fits FAB107, FAB314, and FAB445	0.5 lb.
FAB314	5/8"x12" Galvanized Detachable Step Mount, Double Sided Pole Step, Fits 10" Poles, (CP210 and CP074) Accepts FAB307 Step	2.0 lb.
FAB445	5/8"x10" Galvanized Detachable Single Sided Step Mount, Fits 8" Poles, (CP076) Accepts FAB307 Step	1.8 lb.
FAB446	5/8"x16" Galvanized Permanent Single Sided Climbing Pole Step Fits 8" Pole, (CP076)	2.8 lb.

## ROUND POLE STEP OPTIONS



Part Number	Description	Weight
FAB289*	Single Sided Climbing Step, Stainless Steel for Round Fiberglass Poles, Fits 12" and 16" dia poles (TU450, TU455 and TU460)	.90 lb.
FAB439	Removable Pole Step, Galvanized for Round Fiberglass Poles, Fits 12" and 16" dia poles (TU450, TU455 and TU460), Fits FAB440	.75 lb.
FAB440	Removable Pole Step Mounting Assembly for Round Fiberglass Poles, Fits 12" and 16" dia poles (TU450, TU455 and TU460), Accepts FAB439	1.5 lb.
FAB441	3/4"x 20" Square Head Machine Bolt with Nut HDG (use w/ one FAB462 for single sided step on 12" diameter poles)	2.8 lb.
FAB509	3/4"x 24" Square Head Machine Bolt with Nut HDG (use w/ one FAB462 for single sided step on 16" diameter poles)	3.2 lb.
FAB443	3/4" x 26" Square Head Machine Bolt with Nut HDG (use w/ two FAB462 for double sided step on 12" diameter poles)	3.6 lb.
FAB444	3/4" x 30" Square Head Machine Bolt with Nut HDG (use w/ two FAB462 for double sided step on 16" diameter poles)	4.0 lb.
FAB462	Step Sleeve for Round Poles, use with 3/4" bolts for single and double sided steps on round poles	1.8 lb.
FAB550	Round Pole Step Mount, Fits 10" dia poles, (TU440) Accepts FAB307 Step	3.5 lb.
FAB473	Round Pole Step Mount, Fits 12" dia poles, (TU450 and TU455) Accepts FAB307 Step	3.6 lb.
FAB474	Round Pole Step Mount, Fits 16" dia poles, (TU460) Accepts FAB307 Step	4.0 lb.

\*Non-stocked item.

## WORK INSTRUCTIONS



### 1. TRANSPORTATION AND HANDLING

The composite utility poles are shipped via flatbed truck in bundles to ease the unloading process. A typical package scheme weighs less than 5,000 lbs. and consists of a bundle of 8 to 10 poles. The package is designed to be lifted with a tow motor. However, the package can be picked with a crane or boom truck using a nylon sling. Special shipping requirements must be prearranged with the factory.

When receiving products, all items should be inspected for damage prior to acceptance. If damage has occurred, the user should immediately notify the delivering carrier and complete the necessary freight damage claims. The damage report should indicate what types and level of damage has occurred to the poles. The manufacturer must be notified to discuss the reported damage and help assess the structural integrity of the material for its intended use.



### 2. STORAGE

Composite utility poles can be stored outdoors or indoors. Poles are delivered in bundles to assist in yard storage and minimize pole handling and movement prior to actual delivery to job location. If it is necessary to unpack the poles from the original shipping crates, separate the poles from one another using a similar timber cribbing plan to avoid unnecessary damage to the pole surface. The timber cribbing should also keep the pole high enough above the ground to allow nylon lifting straps to be easily slipped under and around the pole.



### 3. HANDLING INSTRUCTIONS

The identification tag contains the estimated weight of the pole. Composite utility poles can be loaded/moved/unloaded using a forklift positioned perpendicular to the longitudinal axis of the pole and with the load in balance. Care should also be taken in handling to prevent puncturing or cracking a pole with the forklift and to prevent damaging the UV protective surface. It is important to fully position the forklift under the load and lift the pole(s) rather than "slide" the forklift across the flat surface of the pole while in a lifting action. All composite utility poles can be handled utilizing single pick points. The center of gravity on an unframed pole is typically at mid-point of the overall length due to its non-taper design. Significant hardware installations will affect the balance and location of pick when moving a pole. The user should evaluate these weights and adjust the pick point accordingly. Nylon slings should always be used in lieu of chains, cables or other metal hardware when lifting composite utility poles.

The minimal weight of the pole should eliminate the need to drag or skid the pole for any significant distance. If dragging of the pole is necessary for extended lengths due to difficult terrain, the butt of the pole should be protected to avoid excessive damage to the FRP materials and base plug.

## WORK INSTRUCTIONS

### 3. HANDLING INSTRUCTIONS (CONTINUED)

Composite utility poles are NOT solid in cross section. Care should be taken in the lowering of the pole to the ground to facilitate the removal of the handling slings. Poles should not be dropped from distances or freely dumped from transportation trailers. Poles should be rested to a firm surface with clearance allowed to easily remove the supporting slings.

For short distances, pole dollies and other pole handling vehicles can be used. If pole dollies are used, nylon straps should be used in lieu of metal chains to secure the pole. Because composite utility poles are lightweight, some distribution size poles can be manually carried short distances between the staging area and the installation site. Craft persons using shorter nylon slings can carry the pole manually. Pole climbing hardware is also a means of “handling” a pole for manual carry.

### 4. FRAMING

Most standard, non-cleat line hardware can be used on composite utility poles with conventional fasteners and practices. In general, the poles will accept most of the hardware that is used on wood, steel, or concrete poles. However, washers that conform to the pole surface should be used beneath the bolt head and nut. CPI recommends washers matching the contour of the poles be used for all installations. Washer sizes should be selected by reviewing the Washer Pull Through Capacity charts on Page 15.

The preferred method of attachment is with through bolts. There is no need to over torque the nuts as the dimensional characteristics of the composite utility pole will not change significantly due to moisture or temperature. The maximum torque applied is recommended not to exceed 50 ft-lbs. A good rule of thumb is that a lineman should hand tighten the nut and then turn the nut half to one complete turn for proper bolt tension. If over tightening occurs, the pole will oval shape and structural failure could occur.

The following hardware features are not compatible with the CPI composite utility poles:

- Lag bolts: Use a through bolt instead.
- Teeth: Hardware that is drawn into a wood pole should not be used on a composite utility poles. In almost every case, a similar piece of hardware exists that does not have teeth.
- Nails and Staples: Use self-tapping screws.



## WORK INSTRUCTIONS

### 5. FIELD DRILLING HOLES AND CUTTING POLES

CPI will pre-drill holes per customer specifications in the production plant with Computer Numerical Control (CNC) equipment. Holes can be drilled in the field with either hardened high-speed steel (HSS) twist drills, carbide tipped twist drills or self-centering hole-saws. Diamond coated hole saws, carbide tipped twist drill bits and brad-point HSS twist drills perform best. The number of holes needed determines drill selection. Carbide or diamond type drills are recommended for quantities above 20. CPI recommends B & A Manufacturing Company (<http://www.bamanufacturing.com>), FGH series drill bits, for applications that require multiple holes in a short period of time. Many contractors and utilities have had success when utilizing the FGH series drill bits. The bits will save time and drill thousands of holes before needing replaced.

Minimum hole spacing shall be selected by referencing the Edge Distance Chart on Page 14.

Composite utility poles can be field cut with a concrete, skill, or reciprocating saw. An abrasive blade should always be used. Concrete saws work the best and can be utilized with a standard concrete cutting blade. During drill and sawing operations dust will be emitted. The dust is considered a nuisance dust, which can irritate your eyes and skin. Therefore, safety glasses, gloves and long sleeve shirts are recommended during the cutting and drilling process. As documented by Occupational Safety & Health Administration (OSHA), FRP dust millings have potential to cause eye, skin, and upper respiratory tract irritation.

- Cause - mechanical-irritant properties of the glass fibers.
- FRP particulate is non-hazardous.
- FRP particulate is greater than 6 microns; therefore, it cannot reach the alveoli.
- The International Agency for Research on Cancer (IARC) classified FRP particulate as non-cancer causing in June of 1987.

For additional information involving OSHA's dust statement visit the following web sites:

[http://www.osha.gov/pls/oshaweb/owadisp.show\\_document?p\\_table=STANDARDS&p\\_id=9994](http://www.osha.gov/pls/oshaweb/owadisp.show_document?p_table=STANDARDS&p_id=9994)

[http://www.osha.gov/dsg/topics/silicacrystalline/dust/chapter\\_1.html](http://www.osha.gov/dsg/topics/silicacrystalline/dust/chapter_1.html)



### 6. CLIMBING

Climbing provisions are available as permanent or removable steps. CPI offers an array of step options that can be viewed in the Hardware Options Section of this brochure. Climbing positions are usually vertically spaced every 15 to 18 inches and are oriented at 180 degrees (each side of a pole) to each other. "Stepping" positions and "working" positions (steps at the same elevation) can be specified by the user at the time of order. The holes can then be factory drilled and steps attached prior to delivery of the poles.



## WORK INSTRUCTIONS



### 7. ERECTION

Composite utility poles are generally faster and safer to install than wood, steel or concrete poles. Conventional equipment and practices can be used as required for the terrain and site conditions. They can be erected using a single pick point as determined by the weight of the pole and any framed hardware. Nylon chokers should be used by the method of “choking the pole” to secure the pole to the lifting cable; this practice avoids scratching and gouging the pole finish. Never use a chain or steel choker to pick or unload a composite utility pole. A nylon strap, preferably with a neoprene skin, is recommended. This will reduce the chance of the pole sliding during the picking process. CPI prefers to use handling slings, made by Lift-It® (<http://www.lift-it.com>). The slings must be double wrapped and the manufacturer’s recommendations must be followed.



### 8. DIRECT EMBEDMENT

CPI composite utility poles have been designed to be directly embedded in the ground in the same manner as wood poles. Composite utility poles are inert. Therefore, the poles will not adversely affect the environment nor do they require special protective coatings or treatments before being embedded. Composite utility poles can be directly embedded using the same burial depth as would be used for most other types of poles unless special loading or soil conditions dictate otherwise. Once the pole is placed in the hole, the hole can be backfilled with any material normally used, such as native soil, crushed aggregate, concrete, or structural foam. Backfill tools and techniques for CPI composite utility poles are typically the same as those used for wood poles. Care should be taken to avoid impacting the pole wall with tools during backfill and tamping operations. Similar to all tubular poles, a bottom plug is provided to prevent further settling after the composite utility pole has been installed.



### 9. POLE GROUNDING

Ground wires can be fastened to the pole with copper ground clips and self-tapping screws. Plastic wire molding strips can also be used to secure the ground wire to the pole. These strips contain the ground wire and are easily secured to the pole with a self-tapping screw. Ground wires can also be positioned inside of the pole to discourage theft.

### 10. END OF SERVICE LIFE DISPOSAL

CPI composite utility poles have several disposal options, including:

- Recycle into FRP fillers
- Repurpose
- Landfill (Toxicity Characteristic Leaching Procedure or TCLP) will not leach



## INSPECTION

### VISUAL

Visual inspection is a reliable method for surface damage assessment of a composite utility pole. It can roughly map out an area of surface damage, but will not necessarily reveal information about any underlying damage. Visual inspection of FRP structures by maintenance personnel should include inspection for the following:

- Tracking on material surface.
- Lightning damage.
- Vandalism damage.
- Mechanical impact damage.
- Delamination or cracking evidence of composite.

Items such as scratches, minor nicks and discoloration may be visually evident, but are not considered to have an impact on the structural integrity of the structure.

### TAP TEST

A tap test can be used as a routine test to further check for any suspected localized damage. The test requires an inspector to use a small hammer to tap all around the area of suspected damage. This is a fast, inexpensive and easy way to roughly evaluate the condition of the material and locate suspected delaminations or cracks. Any area of the composite utility pole that has suffered an impact and has internal damage will be evident by a low – shallow sound given off by a tap test. Adversely, areas that are unaffected and structurally sound will be evident by a high pitch sound given by a tap test.

### REPAIRING A DAMAGED POLE

Minor surface scrapes and gouges, cosmetic in nature, can be repaired with surface treatments such as acrylic, or polyurethane paints. Fiberglass wrap systems can repair more severe damage such as delaminations caused by vehicle impacts. Products are available in the market place specially developed for this type of structural and cosmetic repair. These systems are composed of fiberglass and resin materials that are very compatible with FRP used in the manufacturing of the composite utility pole. Repairability of the damaged pole needs to be assessed prior to major repairs to assure structural integrity for continued use. Contact the factory for more detailed information in the event a pole is deemed to be structurally affected by an accident.



## SPECIFYING

This specification is intended to define composite utility poles for the Power Distribution Utility and Telecommunication Companies for procurement purposes.

### 1.0 SCOPE

- 1.1 This specification applies to the material requirements, the manufacture and performance of lightweight non-taper, self-supporting and/or guyed, direct buried composite utility poles.
- 1.2 The composite utility poles shall be designed and deployed for service per requirements in accordance with IEEE NESC with reference to ANSI Standard 05.1 for class designation, unless otherwise specified by the user.
- 1.3 The pole and connection nominal strengths shall be published per the National Electric Safety Code (NESC) requirements of expressing the nominal strengths per a 5% lower exclusion limit (LEL).

### 2.0 MATERIAL DESIGN

- 2.1 The one piece pultruded pole shaft shall be constructed by the pultrusion process using a polymer binder containing a minimum 65% "E-CR" or "E" fiberglass by weight. All composite utility poles are manufactured with electrical grade E-glass reinforcements in the form of unidirectional roving, Continuous Filament Mat (CFM) and stitched fabric mats. All E-glass reinforcements meet a minimum tensile strength of 290 ksi per ASTM D2343. The fiberglass materials shall be continuously applied in uni-directional and angular orientations of 0°, ±45°, and 90° to the longitudinal pole neutral axis with uniform tension by the pultrusion process.
- 2.2 The composite utility poles shall be pultruded with a high performance VE resin that is based on a bisphenol-A epoxy matrix. The VE resin shall be utilized for its superior toughness and fatigue attributes. The VE resin provides fire retardant properties that permit the pole to "self extinguish" in the event of a brush fire. Poles shall be classified as "self extinguishing" per UL94 with a V0 rating. The flame spread shall be class I per ASTM E-84 with a Flame Spread Index (FSI) of 25 or less.
- 2.3 Composite utility poles shall contain three layers of UV protection. First, UV Light Absorbers shall be mixed into the thermoset resin, prior to production, and shall function as long term light stability promoter. Second, the composite utility poles shall be encompassed with a 10 mil polyester surfacing veil. The 10 mil veil shall create a resin rich surface and protect the glass reinforcements from fiber blooming. Third, the composite utility poles shall be coated with a 3 mil (wet) high performance paint or powder coat, providing the final layer of UV protection.

### 3.0 STRENGTH & STIFFNESS PROPERTIES

- 3.1 Pole strength shall be specified in pounds (Newtons) and/or moment strength capacity at the pole ground line by applied loads to the pole tip as determined by physical cantilever testing in accordance with the principles set forth in ASTM D1036.
- 3.2 The permitted nominal loads shall be published in terms of the 5th percentile nominal strength or 5% LEL as required per the NESC code. ASCE-111 may be used for providing information for determining the 5% lower exclusion limit strength.

## SPECIFYING

### 4.0 FINISH

- 4.1 The surface of the composite utility pole shall contain a UV resistant, resin rich, smooth and aesthetically pleasing finish uniform along the entire pole length. The poles shall be brown-gray. The composite utility poles shall be manufactured and visually inspected in accordance with ASTM D4385. The composite utility poles shall be coated with a three mil (wet) high performance paint for optimal UV protection.

### 5.0 FRAMING AND ATTACHMENTS

- 5.1 Holes: The composite utility pole shall be predrilled as requested in accordance to customer specifications.
- 5.1.1 Equipment attachment holes shall be drilled at the specified diameters per the provided framing drawings.
- 5.2 Steps: The customer may specify climbing steps as required per configurations available.
- 5.2.1 Step attachment levels shall be drilled per the provided frame drawings.
- 5.2.2 Pole and designated step to support a minimum of 750 pounds (340 kg) of vertical loading at the furthest location of the step adjacent to the pole face.
- 5.3 The composite utility pole shall be supplied with a removable top cap matching the pole profile geometry, securely attached for shipment and delivery.
- 5.4 The composite utility pole shall be supplied with an installed base plug. Pole base closure to be oversized to the composite utility pole geometry with an intermittent interference fit or with a water egress hole to allow moisture to egress from pole interior.
- 5.5 Pole Guying: Guying is determined and designed using normal construction practices as dictated by user standards. Follow the instructions provided by the manufacturer to apply guy loads to the CPI poles.

### 6.0 MANUFACTURING TOLERANCES

- 6.1 Pole Length  $\pm 2"$  (50 mm).
- 6.1.1 Squareness of end cut:  $1/4"$  (6.35 mm).
- 6.1.2 Hole Diameter:  $\pm 1/32"$  (0.8 mm).
- 6.1.3 Hole Location between through holes (opposite sides):  $\pm 1/8"$  (3.2 mm).
- 6.1.4 Hole location centered across flats (Octagonal poles only):  $\pm 1/16"$  (1.5 mm).
- 6.1.5 Hole Location within a group of holes:  $\pm 1/16"$  (1.5 mm).
- 6.1.6 Hole Location between groups:  $\pm 1"$  (25 mm).
- 6.1.7 Hole location from top of pole for the first grouping of holes:  $\pm 2"$  (50 mm).
- 6.1.8 All hardware assemblies must be bolted with at least one full nut engaged into the threads.
- 6.1.9 Pole profile dimensions per ASTM D 3917.
- 6.1.10 Straightness:  $.030"/ft.$  (2.5mm/m) measured with weight minimizing.
- 6.1.11 Weight:  $\pm 10\%$ .

## SPECIFYING

### 7.0 IDENTIFICATION

- 7.1 Each composite utility pole shall be provided with a permanent stainless steel identification tag. It shall contain the customer name, manufacturer's name, pole serial number, month and year of manufacture, class and height of the pole. The tag shall be installed with stainless steel rivets at a distance from pole butt as specified by the utility.

### 8.0 SHIPPING

- 8.1 Crated composite utility poles shall be individually protected in cardboard or equivalent protective material in areas in which dunnage makes contact with poles.
- 8.2 Composite utility poles shall be crated in bundles for ease of handling and transfer without damage to the poles by lifting equipment.

### 9.0 QUALITY ASSURANCE

- 9.1 Quality Assurance shall be performed as described in the organizations quality plan, as approved by the utility.



## SUPERLIGHT SEGEMENTED POLE ANSI O5.1 Class 5

CPI offers a Verizon approved segmented composite utility pole for limited access installations. The SUPERLIGHT pole is lightweight and easy to install.

### POLE SPECIFICATION

The segmented poles shall be manufactured with a VE matrix and reinforced with E-glass fiberglass satisfying the requirements of ASTM D578. The pole shall be octagonal with a nominal wall thickness of 0.25". The pole assembly shall be capable of meeting the strength requirements of an ANSI O5.1 Class 5 pole.

#### Minimum Mechanical Properties

Flex Strength per ANSI O5.1 – 46,999 psi (324 Mpa)  
 Min. Compression Strength per ANSI O5.1 – 46,999 psi (324 Mpa)  
 Ultimate Moment Capacity 59,611 lb-ft. – (80.8 kN·m)

#### Minimum Physical Properties

Moment of Inertia – 60.87 in<sup>4</sup>  
 Section Modulus – 15.22 in<sup>3</sup>

#### Fire Performance (CP076)\*

UL 94 Rating - V0  
 ASTM D635 - Self Extinguishing  
 ASTM E84 - Class A

\* Fire performance based on CP076 8" pole only, splice and caps are exempt.

### ASSEMBLY INSTRUCTIONS

The segmented composite utility pole is shipped assembled and ready for installation. In the event the pole needs to be partially or fully disassembled perform the following:

- 1.0 Position the assembled pole on blocks of wood in an area with enough clearance to allow the pole to be slid apart (min. of 24").
- 2.0 Back out the self drilling assembly screws that connect the pole segment that you wish to disassemble.
- 3.0 Slide the pole apart.
- 4.0 Transport the pole components to the assembly location and reassemble the pole.



### POLE ASSEMBLY

POLE DESCRIPTION	CPI Assembly Part Number	Assembled Pole Weight (lbs)	Assembly Sections	Part Number	Quantity	Weight
25' long ANSI O5.1 Class 5 3-SECTION POLE	PT2505	238	8" utility pole 8'-4" in length 36" long external FRP splice	CP076 FAB390	3 2	51.3 lb. 32 lb.
30' long ANSI O5.1 Class 5 3-SECTION POLE	PT3005	274	8" utility pole 10' in length 36" long external FRP splice	CP076 FAB390	3 2	70 lb. 32 lb.
35' long ANSI O5.1 Class 5 4-SECTION POLE	PT3505	340	8" utility pole 8'-4" in length 8" utility pole 10' in length 36" long external FRP splice	CP076 CP076 FAB390	3 1 3	51.3 lb. 70 lb. 32 lb.

Note: Each pole is shipped assembled with caps and self drilling screws.

# SUPERLIGHT SEGEMENTED POLE

## SPlice DETAIL

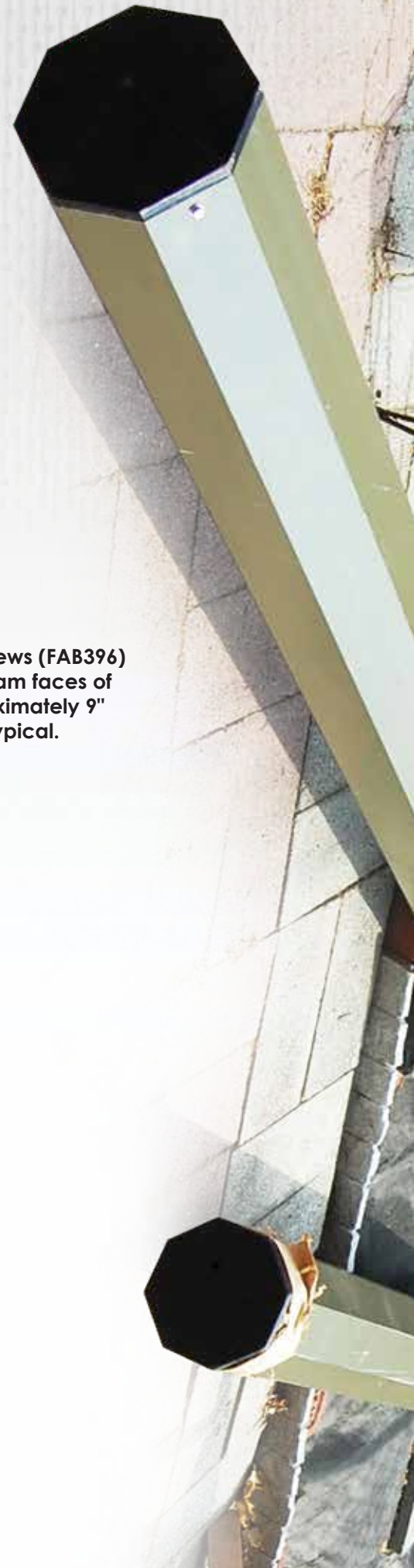
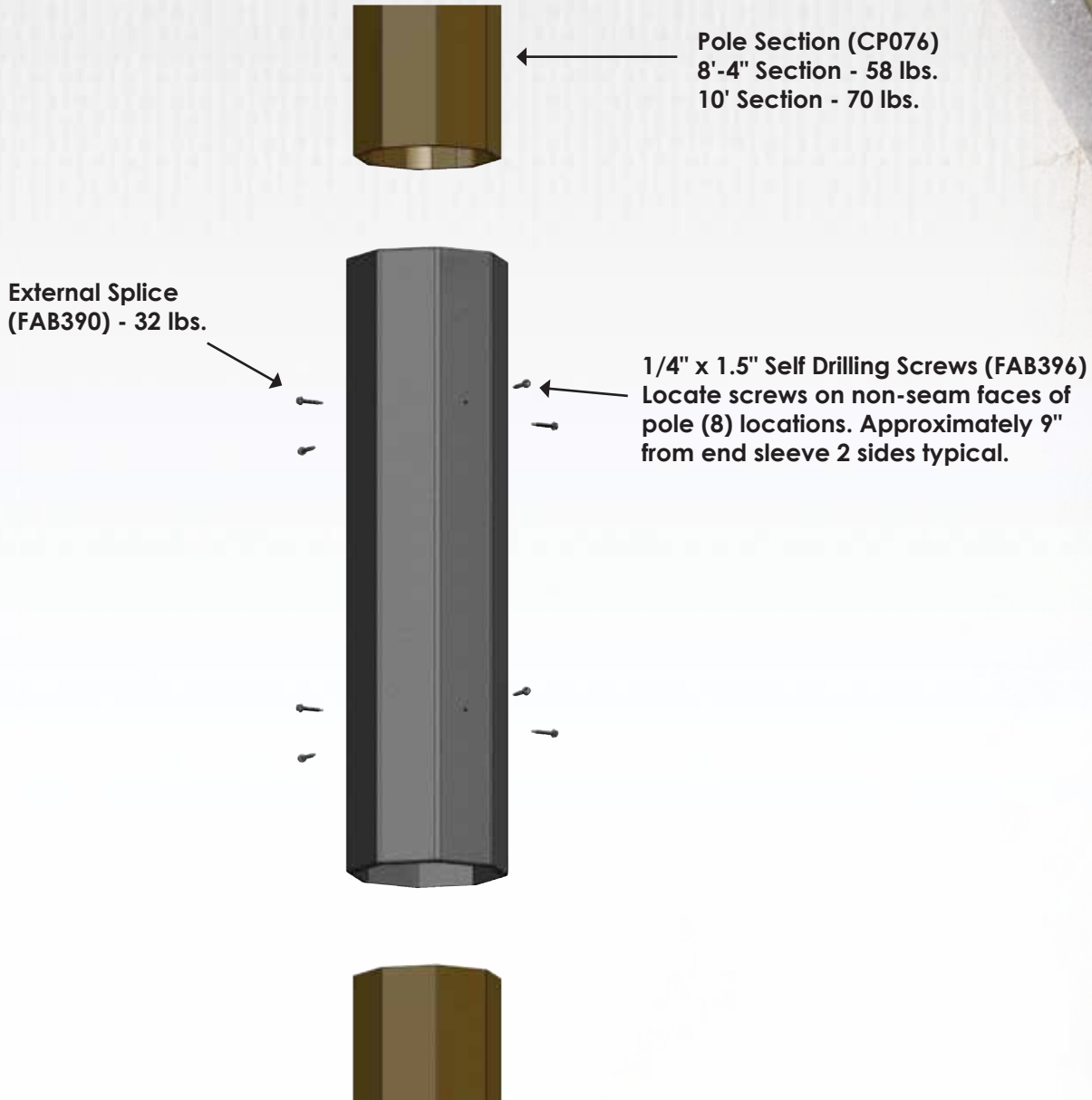

# ORDERING PART NUMBER SYSTEM

Type	Pole Length (ft)	Pole Class (ANSI O5.1)	Pole Section <sup>1</sup>	Resin	Pole Color <sup>2</sup>	No. of Holes Drilled in Pole
PT = Octagonal Pole CP = Round Pole	20 25 30 35 40 45 50 55 60 65 70 Etc.	06 = 1,500 lbs 05 = 1,900 lbs 04 = 2,400 lbs 03 = 3,000 lbs 02 = 3,700 lbs 01 = 4,500 lbs H1 = 5,400 lbs H2 = 6,400 lbs H3 = 7,500 lbs H4 = 8,700 lbs H5 = 10,000 lbs	CP076 CP074 CP210 TU440 TU455 TU450 TU460	3 3 3 2 3 3 3	B2 = Brown Gray RAL 7013 (Standard Color) 02 = Light Gray D1 = Brown RAL 8014	

**Notes:**

- 1.0 Reference Pole Load Charts to Select the Proper Pole Section.
- 2.0 Finish color is the exterior coating color of the pole.

Download the hardware catalog and customer requirement utility pole fabrication sheet from CPI's web site <http://www.creativepultrusions.com/pultruded-systems/composite-utility-poles/> to begin the ordering process today.

214 Industrial Lane, Alum Bank, PA 15521

Phone 814.839.4186 • Fax 814.839.4276 • Toll Free 888.CPI.PULL

[www.creativepultrusions.com](http://www.creativepultrusions.com) • [www.powertrusion.com](http://www.powertrusion.com)



PLEASE SCAN WITH PHONE

For additional information about CPI composite utility poles, or to learn how to lower your costs while increasing performance, contact a technical representative at 888-CPI-PULL (274-7855), or visit our website at [www.creativepultrusions.com](http://www.creativepultrusions.com).

---

## Appendix II – ComEd Detail C9075

# FIBERGLASS DECORATIVE STREET LIGHTING

## UNDERGROUND FEED

### 120 VOLT OPERATION

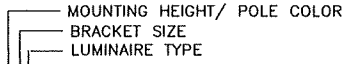

- C9075
- .A\_\_\_ FIBERGLASS POLE, 25 FT. MOUNTING HEIGHT, DARK BRONZE
  - .B\_\_\_ FIBERGLASS POLE, 25 FT. MOUNTING HEIGHT, GRAY
  - .C\_\_\_ FIBERGLASS POLE, 30 FT. MOUNTING HEIGHT, DARK BRONZE
  - .D\_\_\_ FIBERGLASS POLE, 30 FT. MOUNTING HEIGHT, GRAY
  - ..A\_ 8 FT MAST ARM
  - ..B\_ 10 FT MAST ARM
  - ..C\_ 12 FT MAST ARM
  - ...A LUMINAIRE, COBRA-HEAD, HIGH PRESSURE SODIUM (HPS)
  - ...B LUMINAIRE, COBRA-HEAD, LIGHT EMITTING DIODE (LED)

ITEM	CAT ID DESCRIPTION TABLE-1	CAT ID	UNIT	QUANTITY					
				.AA_	.AB_	.AC_	.BA_	.BB_	.BC_
A	POLE, FIBERGLASS, 30 FT. GRAY, ROUND TAPERED, SMOOTH FINISH, D	0001638852	EA				1	1	1
	POLE, FIBERGLASS, 30 FT. DARK BRONZE, ROUND TAPERED, SMOOTH FI	0001638851	EA	1	1	1			
B	AGGREGATE, FOUNDATION, GRADE 8 OR 9, PACKAGED IN 7 MIL POLYETH	0000701119	BG	13	13	13	13	13	13
C	BRACKET, STREET LIGHT, 10 FT. ALUMINUM, MOUNTS ON FIBERGLASS P	0001638846	EA		1			1	
	BRACKET, STREET LIGHT, 12 FT. ALUMINUM, MOUNTS ON FIBERGLASS P	0001638847	EA			1			1
	BRACKET, STREET LIGHT, 8 FT. ALUMINUM, MOUNTS ON FIBERGLASS PO	0001638845	EA	1			1		
D	CONNECTOR, STREET LIGHT, #2-14, SET-SCREW, ALUMINUM, 4 POSITIO	0001641530	EA	2	2	2	2	2	2
E	CABLE,COPPER, CONTROL & INSTRUMENT, 600V CONTROL, #10-2/C, STR	0000363582	FT	52	54	56	52	54	56

ITEM	CAT ID DESCRIPTION TABLE-1 (CONT'D)	CAT ID	UNIT	QUANTITY					
				.CA_	.CB_	.CC_	.DA_	.DB_	.DC_
A	POLE, FIBERGLASS, 35 FT. GRAY, ROUND TAPERED, SMOOTH FINISH, D	0001638849	EA				1	1	1
	POLE, FIBERGLASS, 35 FT. DARK BRONZE, ROUND TAPERED, SMOOTH FI	0001638850	EA	1	1	1			
B	AGGREGATE, FOUNDATION, GRADE 8 OR 9, PACKAGED IN 7 MIL POLYETH	0000701119	BG	13	13	13	13	13	13
C	BRACKET, STREET LIGHT, 10 FT. ALUMINUM, MOUNTS ON FIBERGLASS P	0001638846	EA		1			1	
	BRACKET, STREET LIGHT, 12 FT. ALUMINUM, MOUNTS ON FIBERGLASS P	0001638847	EA			1			1
	BRACKET, STREET LIGHT, 8 FT. ALUMINUM, MOUNTS ON FIBERGLASS PO	0001638845	EA	1			1		
D	CONNECTOR, STREET LIGHT, #2-14, SET-SCREW, ALUMINUM, 4 POSITIO	0001641530	EA	2	2	2	2	2	2
E	CABLE,COPPER, CONTROL & INSTRUMENT, 600V CONTROL, #10-2/C, STR	0000363582	FT	52	54	56	52	54	56

ITEM	CAT ID DESCRIPTION TABLE-2	CAT ID	UNIT	QUANTITY	
				...A_	...B_
G	COBRA HEAD LED LUMINAIRE C9033. ---				1
	COBRA-HEAD LUMINAIRE C9037. _			1	

**NOTES:**

APPLICATION

- THIS STANDARD SHALL BE USED TO INSTALL FIBERGLASS POLE MOUNTED DECORATIVE STREET LIGHTING FOR MUNICIPAL FIXTURE INCLUDED LIGHTING CUSTOMERS.

SUPPLEMENTARY MATERIAL

- 1 RECESSED HANDHOLE AND COVER PLATE, GROUND WIRE, AND TAMPERPROOF SCREWS INCLUDED AS POLE ACCESSORIES.
- 2 REPLACEMENT HANDHOLES COVERS ARE AVAILABLE:
  - DARK BRONZE (CAT ID 0001639674)
  - GRAY (CAT ID 0001639675)

INFORMATION

- 11 LOCATE POLES A MINIMUM OF 30 INCHES BACK FROM CURB.
- 12 HOLE SHALL BE APPROXIMATELY 15 INCHES IN DIAMETER. POLE SHALL BE INSTALLED WITH A SETTING DEPTH OF 5 FEET. BACKFILL WITH AGGREGATE, ITEM "B".
- 13 STREET LIGHT POLES ARE TYPICALLY RADIALLY FED FROM SERVICE PEDESTALS USING 2-1/C #6 AL 600 VOLT CABLE (CAT ID 0000361024). ADDITIONAL STREET LIGHTS MAY BE WIRED VIA USE OF CONNECTORS, ITEM "D".

ACAD



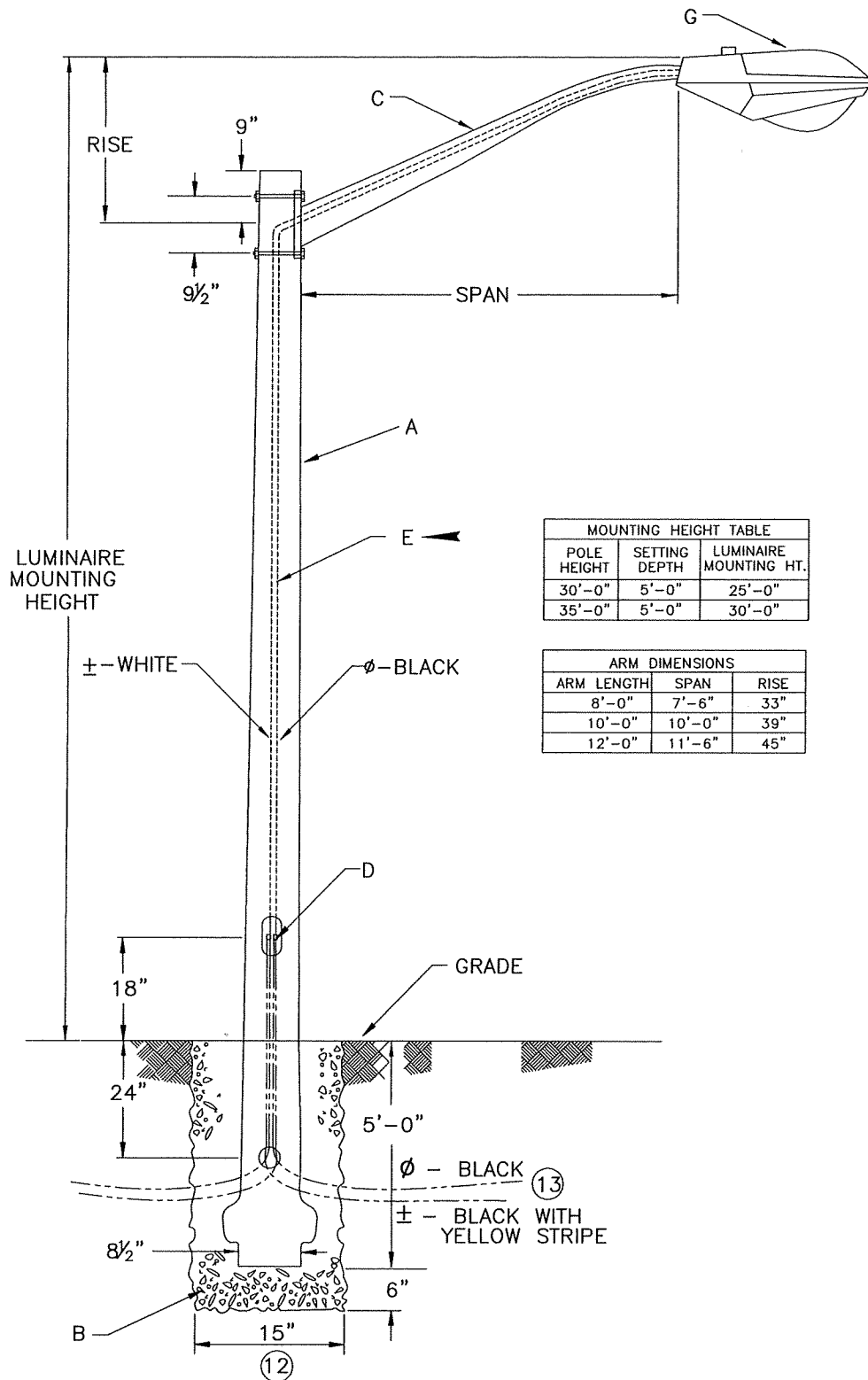

**C9075. FIBERGLASS POLE WITH MAST ARM**

ACAD

---

## Appendix III – Downtown Crystal Lake District Detail

# POST TOP DECORATIVE OUTDOOR LIGHTING

## HIGH PRESSURE SODIUM (HPS) AND LIGHT EMITTING DIODE (LED)

### 120 VOLT OPERATION

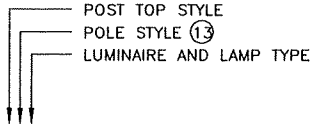

- C9069.A\_\_\_ ACORN STYLE - SINGLE FIXTURE  
 .B\_\_\_ ACORN STYLE - DOUBLE FIXTURE  
 .C\_\_\_ EARLY AMERICAN STYLE

- ..A. BLACK FIBERGLASS, FLUTED, 13'-6"  
 ..B. BLACK FIBERGLASS, FLUTED, 18'-6"  
 ..C. BLACK FIBERGLASS, SQUARE, NATURAL FINISH, 20'  
 ..D. BLACK FIBERGLASS, ROUND, SMOOTH FINISH, 20'  
 ..E. BLACK FIBERGLASS, ROUND, NATURAL FINISH, 20' (PREFERRED CONSTRUCTION (15))  
 ..F. HEXAGONAL, CONCRETE, 20'

- ..A ACORN, HPS, 100W, SINGLE FIXTURE  
 ..B ACORN, HPS, 100W, DOUBLE FIXTURE  
 ..C ACORN, LED, 40-60W, SINGLE FIXTURE  
 ..D ACORN, LED, 40-60W, DOUBLE FIXTURE  
 ..E EARLY AMERICAN, HPS, 100W  
 ..F EARLY AMERICAN, LED, 40-60W

ITEM	CAT ID DESCRIPTION	TABLE-1 (HIGH PRESSURE SODIUM)	CAT ID	UNIT	QUANTITY								
					.AAA	.ABA	.BAB	.BBB	.CCE	.CDE	.CEE	.CFE	
A	CONNECTOR, STREET LIGHT, #2-14, SET-SCREW, ALUMINUM, 4 POSITIO		0001641530	EA	2	2	2	2	2	2	2	2	2
B	CONTROL, PHOTOELECTRIC, STREET LIGHT, ELECTRONIC, BLACK HOUSIN		0000434100	EA	1	1	2	2	1	1	1	1	1
C	AGGREGATE, FOUNDATION, GRADE 8 OR 9, PACKAGED IN 7 MIL POLYETH		0000701119	BG	10	10	10	10	10	10	10	10	10
D	CABLE,COPPER, CONTROL & INSTRUMENT, 600V CONTROL, #10-2/C, STR		0000363582	FT	25	25	50	50	25	25	25	25	25
F	BRACKET, STREET LIGHT, 30 IN. WIDE X 11-1/2 IN. HIGH, 3 IN. DI		0000431014	EA			1	1					
G	POLE, FIBERGLASS, 9.5 FT MOUNTING HEIGHT, FLAT BLACK FLUTED, *		0000431016	EA	1		1						
	POLE, FIBERGLASS, 14.5 FT MOUNTING HEIGHT, FLAT BLACK FLUTED,		0000431019	EA		1		1					
H	POLE, FIBERGLASS, 20 FT. ROUND, TAPERED, BLACK, SMOOTH FINISH,		0000431018	EA						1			
	POLE, FIBERGLASS, 20 FT. ROUND, TAPERED, BLACK, NATURAL FINISH		0000431021	EA							1		
	POLE, CONCRETE, 20 FT STREET LIGHT, DIRECT BURIAL, PRESTRESSED		0000431050	EA									1
	POLE, FIBERGLASS, 20 FT. SQUARE, TAPERED, BLACK, NATURAL FINIS		0000431009	EA					1				
N	LUMINAIRE, POST, HPS 100W,120V, BLACK CAST ALUMINUM, POLYCARBO		0000431013	EA	1	1	2	2					
Q	LUMINAIRE, POST, LUMINAIRE, POST HPS 100W, 120V, EARLY AMERICA		0000430520	EA					1	1	1	1	1
R	LAMP, HIGH PRESSURE SODIUM, 100 WATT, CLEAR, MOGUL SCREW BASE,		0000444098	EA	1	1	2	2	1	1	1	1	1

ITEM	CAT ID DESCRIPTION	TABLE-2 (LIGHT EMITTING DIODE)	CAT ID	UNIT	QUANTITY								
					.AAC	.ABC	.BAD	.BBD	.CCF	.CDF	.CEF	.CFF	
A	CONNECTOR, STREET LIGHT, #2-14, SET-SCREW, ALUMINUM, 4 POSITIO		0001641530	EA	2	2	2	2	2	2	2	2	2
B	CONTROL, PHOTOELECTRIC, STREET LIGHT, LONG LIFE, 120V, 1.5 FC		0001616710	EA	1	1	2	2	1	1	1	1	1
C	AGGREGATE, FOUNDATION, GRADE 8 OR 9, PACKAGED IN 7 MIL POLYETH		0000701119	BG	10	10	10	10	10	10	10	10	10
D	CABLE,COPPER, CONTROL & INSTRUMENT, 600V CONTROL, #10-2/C, STR		0000363582	FT	25	25	50	50	25	25	25	25	25
F	BRACKET, STREET LIGHT, 30 IN. WIDE X 11-1/2 IN. HIGH, 3 IN. DI		0000431014	EA			1	1					
G	POLE, FIBERGLASS, 14.5 FT MOUNTING HEIGHT, FLAT BLACK FLUTED,		0000431019	EA		1		1					
	POLE, FIBERGLASS, 9.5 FT MOUNTING HEIGHT, FLAT BLACK FLUTED, *		0000431016	EA	1		1						
H	POLE, FIBERGLASS, 20 FT. ROUND, TAPERED, BLACK, NATURAL FINISH		0000431021	EA							1		
	POLE, FIBERGLASS, 20 FT. ROUND, TAPERED, BLACK, SMOOTH FINISH,		0000431018	EA						1			
	POLE, FIBERGLASS, 20 FT. SQUARE, TAPERED, BLACK, NATURAL FINIS		0000431009	EA					1				
	POLE, CONCRETE, 20 FT STREET LIGHT, DIRECT BURIAL, PRESTRESSED		0000431050	EA									1
N	LUMINAIRE, POST, LED, 40-60 WATT, 120-277V, ACORN STYLE, TYPE		0001643163	EA	1	1	2	2					
	LUMINAIRE, POST, LED, 40-60 WATT, 120-277V, EARLY AMERICAN STY		0001641980	EA					1	1	1	1	1

ACAD

APPLICATION

- THIS STANDARD SHALL BE USED TO INSTALL POST TOP DECORATIVE OUTDOOR LIGHTING FOR RATE BES - PUBLIC STREET LIGHTING CLASS CUSTOMERS.

SUPPLEMENTARY MATERIAL

- 1 FOR "PLUG-IN" STYLE IGNITOR REPLACEMENT FOR GENERAL ELECTRIC HIGH PRESSURE SODIUM FIXTURES, SPECIFY THE FOLLOWING:  
  
75-150 WATT FIXTURE - CAT ID 0000430491  
250-400 WATT FIXTURE - CAT ID 0001613565
- 2 WHEN MERCURY VAPOR REPLACEMENT LAMPS ARE REQUIRED FOR MAINTENANCE, SPECIFY THE FOLLOWING:  
  
100 WATT - CAT ID 0000444049  
175 WATT - CAT ID 0000444033
- ③ WHEN HANDHOLE REPLACEMENT COVERS ARE REQUIRED FOR FIBERGLASS STREET LIGHT POLES, SPECIFY THE FOLLOWING:  
  
CAT ID 0001616761 - FOR BLACK SQUARE POLE  
  
CAT ID 0001616762 - FOR BLACK ROUND POLE  
  
CAT ID 0001616763 - FOR GRAY ROUND POLE

- ⑬ EARLY AMERICAN FIXTURE WILL FIT ANY POLE LISTED; HOWEVER, FOR AESTHETIC REASONS, ONLY THE COMBINATIONS SHOWN IN TABLE 1 AND TABLE 2 ARE RECOMMENDED.
- ⑭ STREET LIGHT POLES ARE TYPICALLY FED DIRECTLY FROM SERVICE PEDESTALS (SEE DETAIL-A). SPECIFY CAT ID 0000361024, 2 CONDUCTOR #6AL. ADDITIONAL STREET LIGHTS MAY BE WIRED USING CONNECTOR SUPPLIED BY THIS STANDARD, ITEM "A".
- ⑮ THE 20 FOOT, ROUND, BLACK, NATURAL FINISH, FIBERGLASS POLE, OPTION C9069.CE\_ IS THE PREFERRED CONSTRUCTION FOR EARLY AMERICAN STYLE POLES.
- ⑯ BOTTOM OF TRENCH SHALL BE UNDISTURBED OR WELL TAMPED EARTH FREE FROM ROCKS AND/OR DEBRIS. BACK FILL SHALL BE DIRT FREE FROM STONES, BROKEN GLASS, CANS AND/OR OTHER DEBRIS THAT MAY DAMAGE THE CABLE. IF THIS IS NOT AVAILABLE, SAND SHALL BE SUBSTITUTED.
- 17 AS MERCURY VAPOR FIXTURES FAIL, THEY SHALL BE REPLACED WITH LED (LIGHT EMITTING DIODE) FIXTURES.

INFORMATION

- ⑪ HOLES SHALL ALLOW A MINIMUM 5 INCHES OF AGGREGATE AROUND BASE OF POLE.
- ⑫ TO TEST PHOTO CONTROL OPERATION (INSTANT ON, 2-5 SECOND TURN OFF DELAY) COVER PHOTO EYE WITH GLOVE. BARE HANDS ARE INEFFECTIVE FOR TESTING PHOTO CONTROL OPERATION.

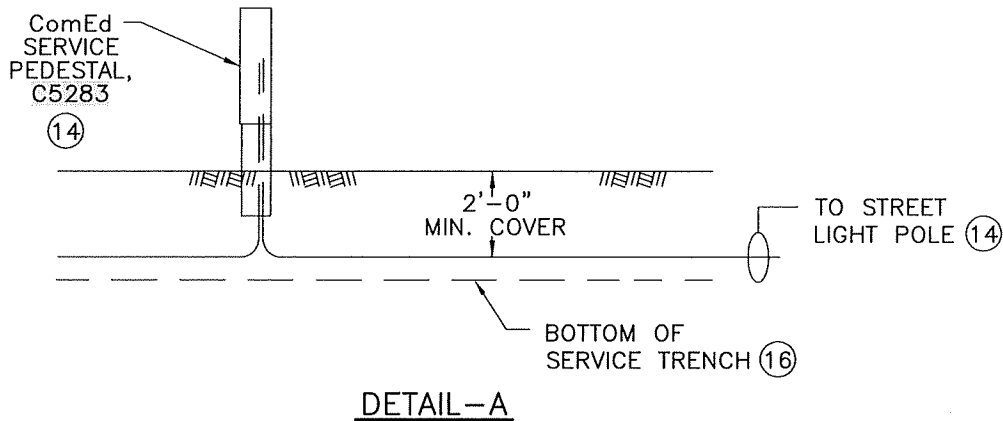

ACAD

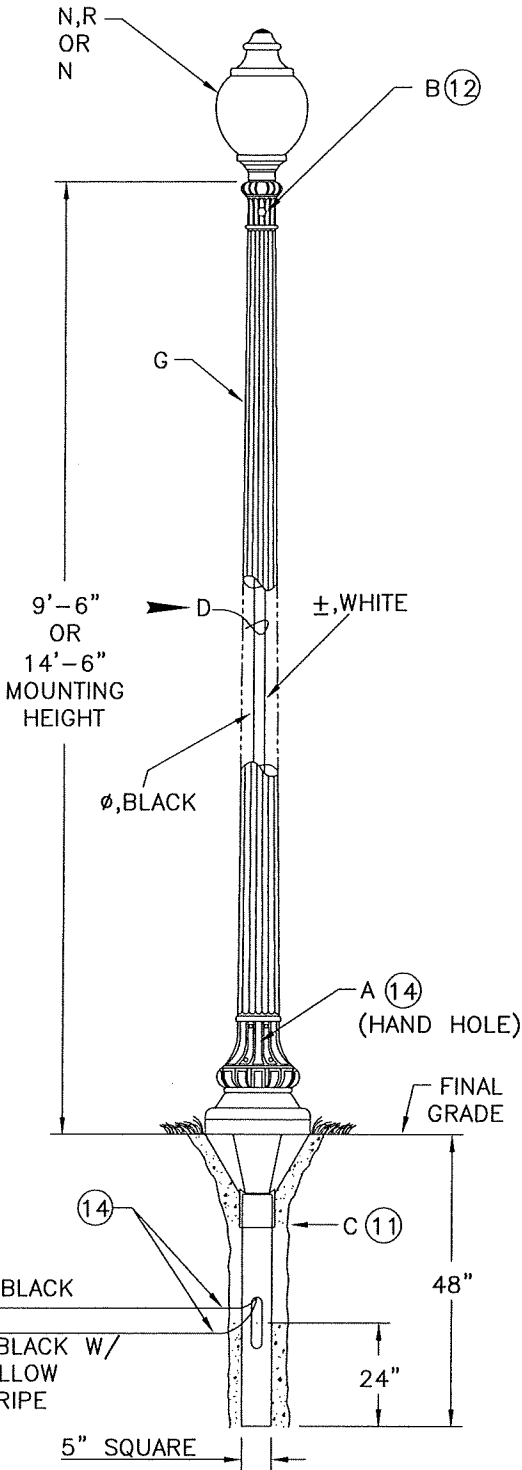

C9069.AA  
C9069.AB

ACORN STYLE-SINGLE FIXTURE  
HPS OR LED

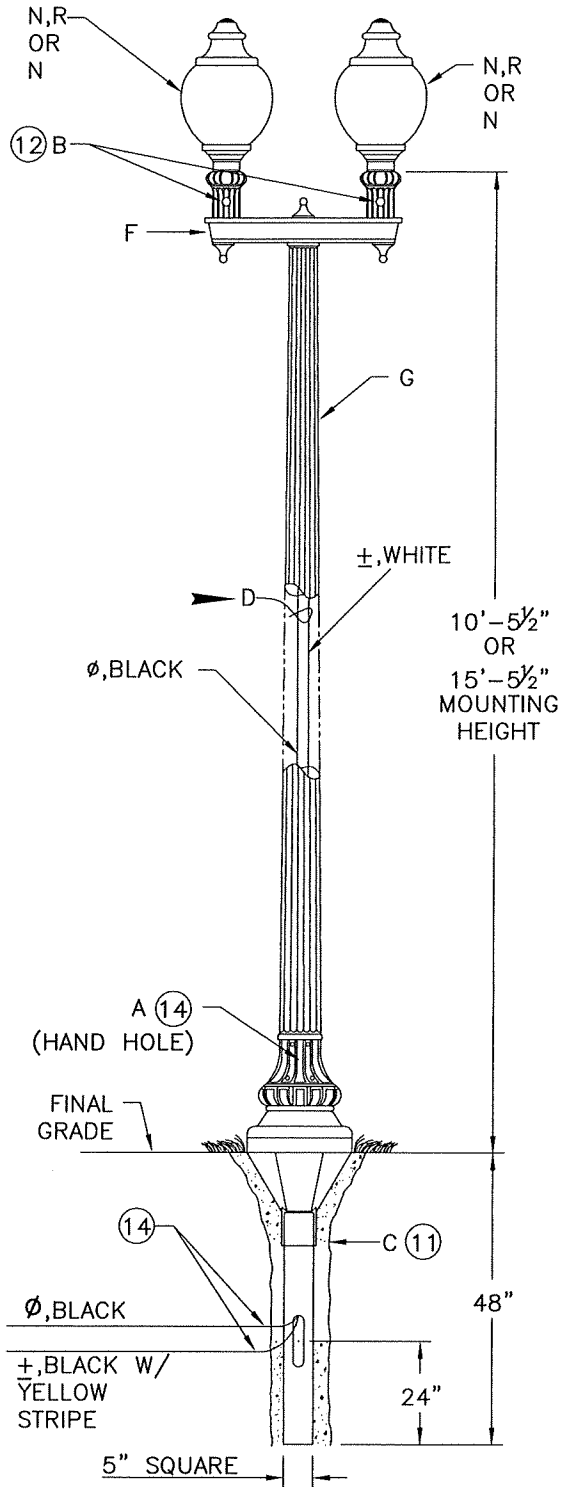

C9069.BA  
C9069.BB

ACORN STYLE-DOUBLE FIXTURE  
HPS OR LED

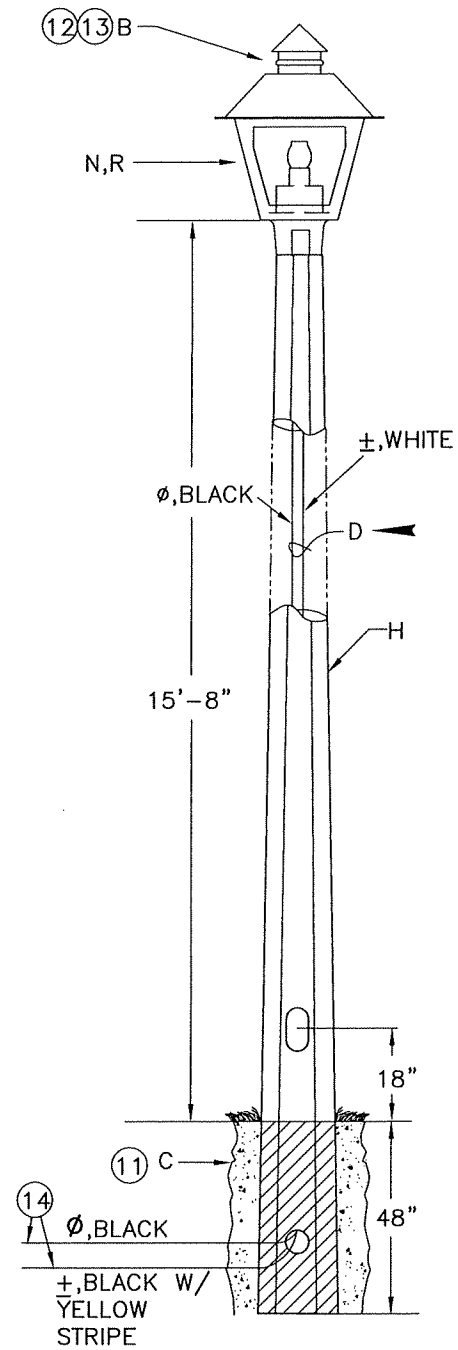
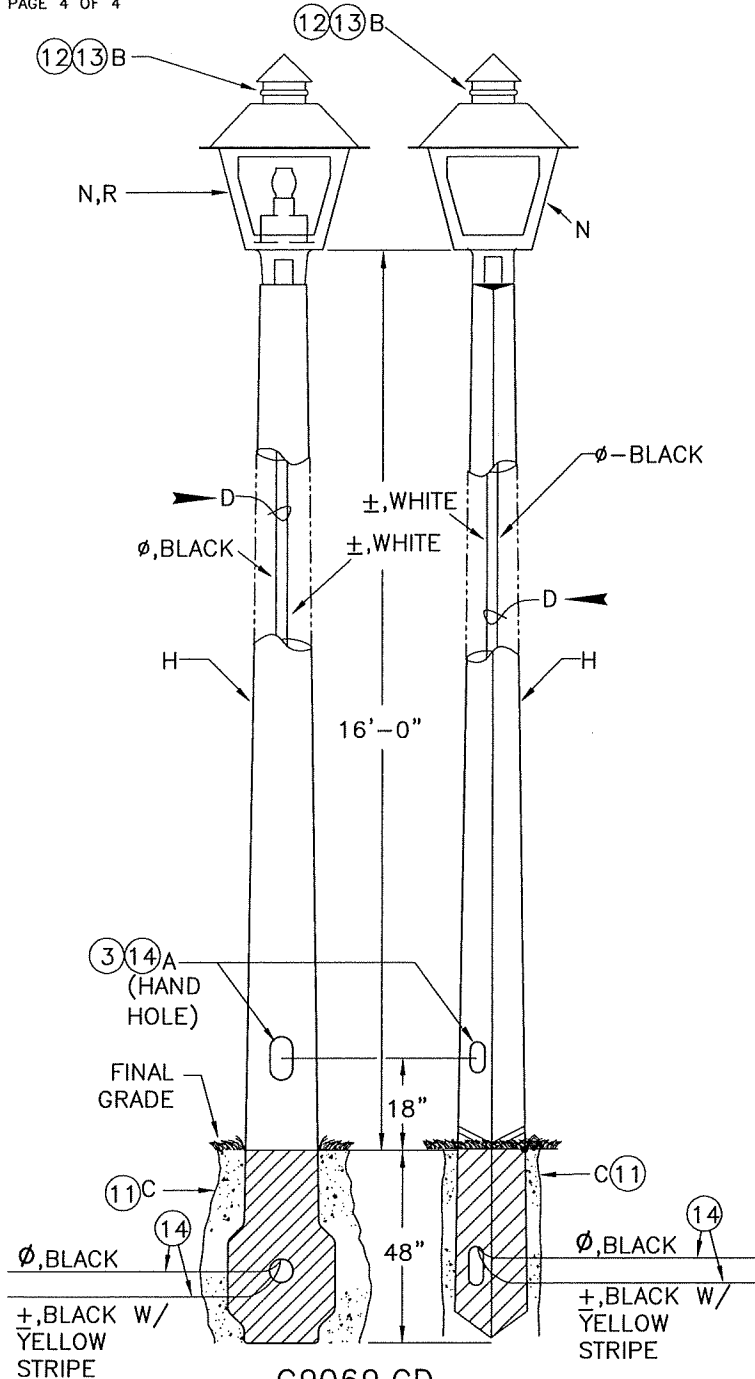

C9069.CD  
C9069.CE (15)

EARLY AMERICAN STYLE FIXTURE  
 ON ROUND FIBERGLASS POLE  
 HPS SHOWN (LEFT)  
C9069.CC

EARLY AMERICAN STYLE FIXTURE  
 ON SQUARE FIBERGLASS POLE  
 LED SHOWN (RIGHT)

C9069.CF

EARLY AMERICAN STYLE  
 FIXTURE ON CONCRETE  
 HEXAGONAL POLE  
 HPS SHOWN

ACAD

© Notice: The information contained on this page is the sole property of ComEd and is to be used only in conjunction with electric service provided by ComEd.

---

## Appendix IV – Virginia Street Corridor Detail





---

## Appendix V – Three Oaks Recreation Area Detail

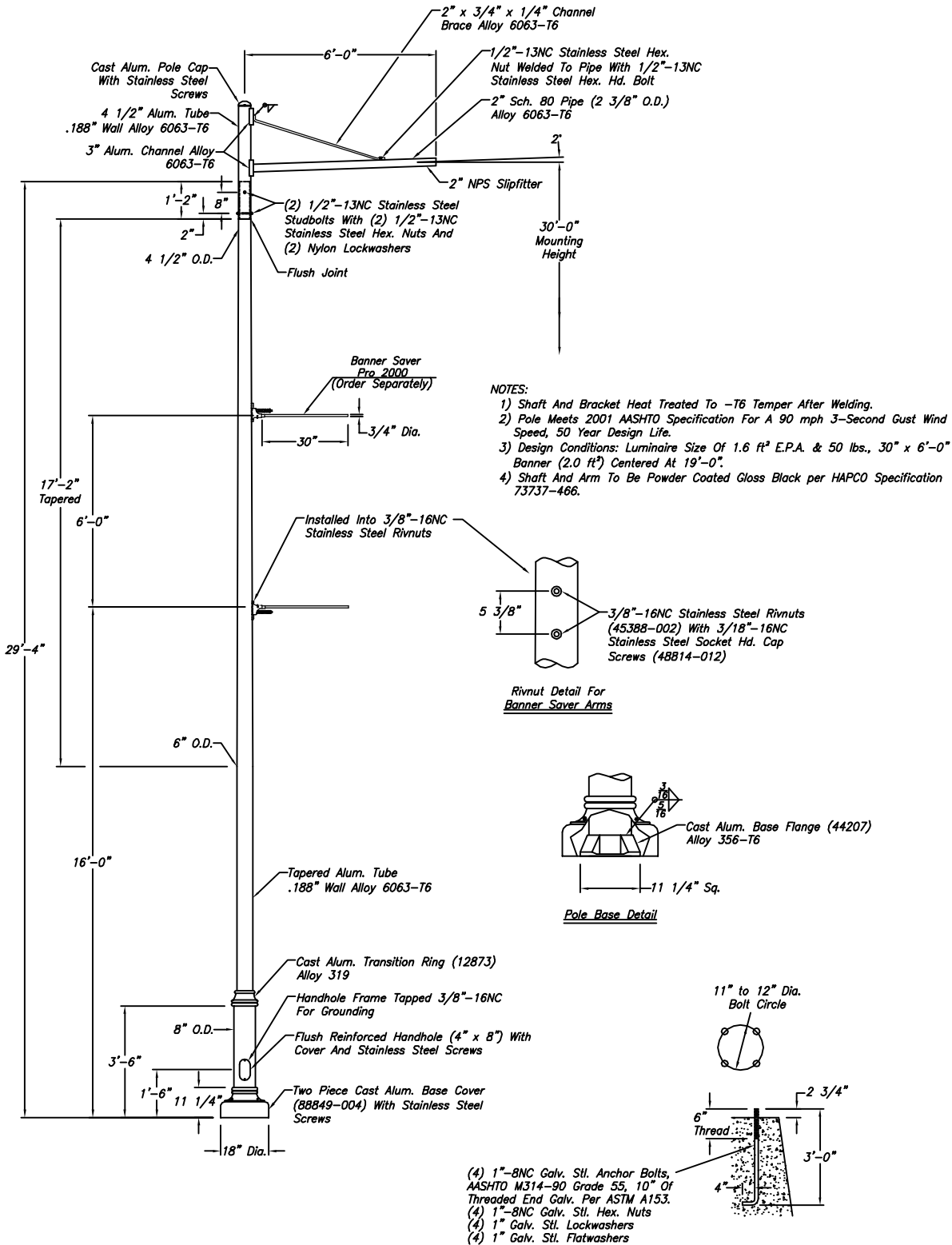

- NOTES:**
- 1) Shaft And Bracket Heat Treated To -T6 Temper After Welding.
  - 2) Pole Meets 2001 AASHTO Specification For A 90 mph 3-Second Gust Wind Speed, 50 Year Design Life.
  - 3) Design Conditions: Luminaire Size Of 1.6 ft<sup>2</sup> E.P.A. & 50 lbs., 30" x 6'-0" Banner (2.0 ft<sup>2</sup>) Centered At 19'-0".
  - 4) Shaft And Arm To Be Powder Coated Gloss Black per HAPCO Specification 73737-466.

B16519

**WARNING: DO NOT INSTALL LIGHTING POLES WITHOUT LUMINAIRES**

NO.	REVISIONS	DATE

**hapco**  
Abingdon, Va.

**TITLE TYPE A1/A4 LIGHTING POLES**

**CUSTOMER Vulcan Lakes, IL**

**SCALE 3/2**      **DATE 03/18/2009**

**BY TNB**      **DWG. NO.**

**CHK'D**      **B16519**

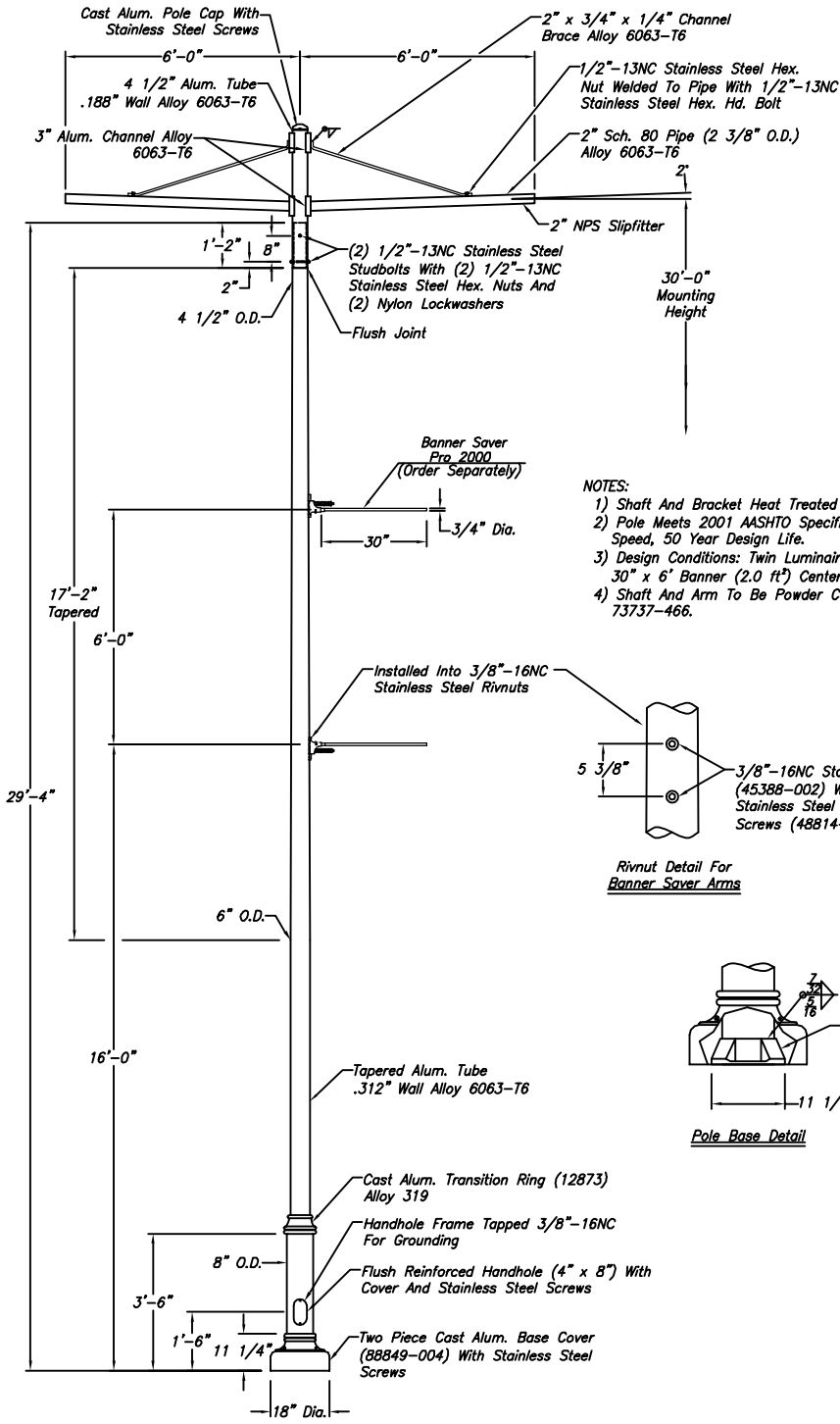

- NOTES:**
- 1) Shaft And Bracket Heat Treated To -T6 Temper After Welding.
  - 2) Pole Meets 2001 AASHTO Specification For A 90 mph 3-Second Gust Wind Speed, 50 Year Design Life.
  - 3) Design Conditions: Twin Luminaire Size Of 1.6 ft<sup>2</sup> E.P.A. (ea.) & 50 lbs. (ea.), 30" x 6" Banner (2.0 ft<sup>2</sup>) Centered At 19'-0".
  - 4) Shaft And Arm To Be Powder Coated Gloss Black per HAPCO Specification 73737-466.

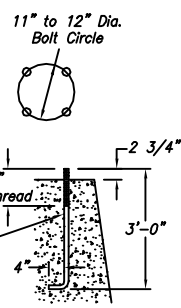
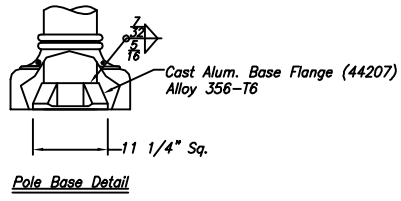
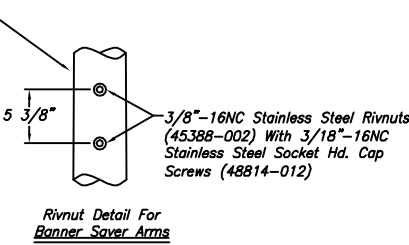

- (4) 1"-8NC Galv. Stl. Anchor Bolts, AASHTO M314-90 Grade 55, 10" Of Threaded End Galv. Per ASTM A153.
- (4) 1"-8NC Galv. Stl. Hex. Nuts
- (4) 1" Galv. Stl. Lockwashers
- (4) 1" Galv. Stl. Flatwashers

B16520

**WARNING: DO NOT INSTALL LIGHTING POLES WITHOUT LUMINAIRES**

NO.	REVISIONS	DATE

**hapco**  
Abingdon, Va.

TITLE TYPE A2 LIGHTING POLES  
CUSTOMER Vulcan Lakes, IL  
SCALE 3/2 DATE 03/18/2009  
BY TNB DWG. NO.  
CHK'D B16520

NOTES:

- 1) Shaft And Bracket Heat Treated To -T6 Temper After Welding.
- 2) Pole Meets 2001 AASHTO Specification For A 90 mph 3-Second Gust Wind Speed, 50 Year Design Life.
- 3) Design Conditions: Luminaire Size Of 1.6 ft<sup>2</sup> E.P.A. & 50 lbs.
- 4) Shaft And Arm To Be Powder Coated Gloss Black per HAPCO Specification 73737-466.

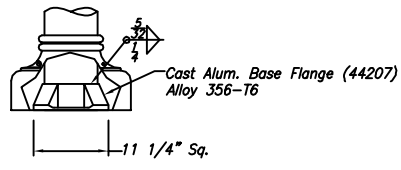
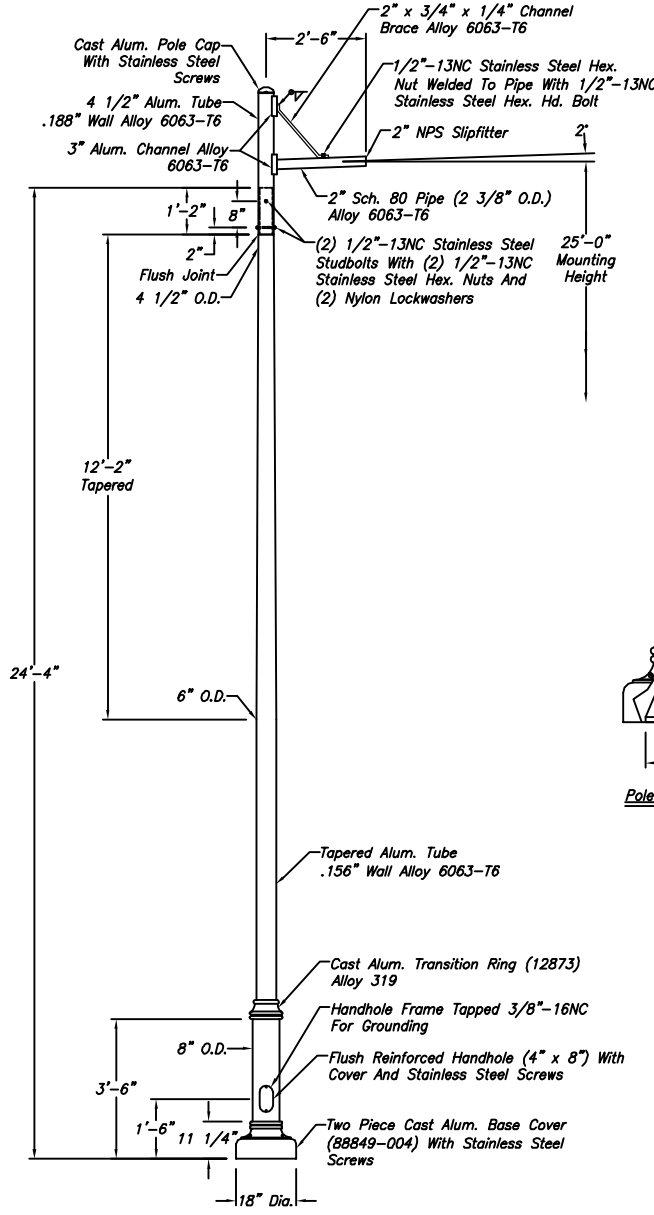

Pole Base Detail

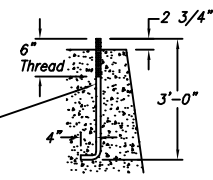
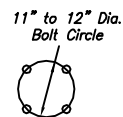

- (4) 1"-BNC Galv. Stl. Anchor Bolts, AASHTO M314-90 Grade 55, 10" Of Threaded End Galv. Per ASTM A153.
- (4) 1"-BNC Galv. Stl. Hex. Nuts
- (4) 1" Galv. Stl. Lockwashers
- (4) 1" Galv. Stl. Flatwashers

B16521

WARNING: DO NOT INSTALL LIGHTING POLES WITHOUT LUMINAIRES

NO.	REVISIONS	DATE

		TITLE TYPE B1 LIGHTING POLES	
		CUSTOMER Vulcan Lakes, IL	
Abingdon, Va.		SCALE 3/2	DATE 03/18/2009
		BY TNB	DWG. NO.
		CHK'D	B16521

NOTES:

- 1) Shaft And Bracket Heat Treated To -T6 Temper After Welding.
- 2) Pole Meets 2001 AASHTO Specification For A 90 mph 3-Second Gust Wind Speed, 50 Year Design Life.
- 3) Design Conditions: Luminaire Size Of 1.6 ft<sup>2</sup> (ea.) E.P.A. & 50 lbs (ea.).
- 4) Shaft And Arm To Be Powder Coated Gloss Black per HAPCO Specification 73737-466.

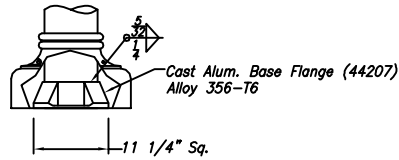
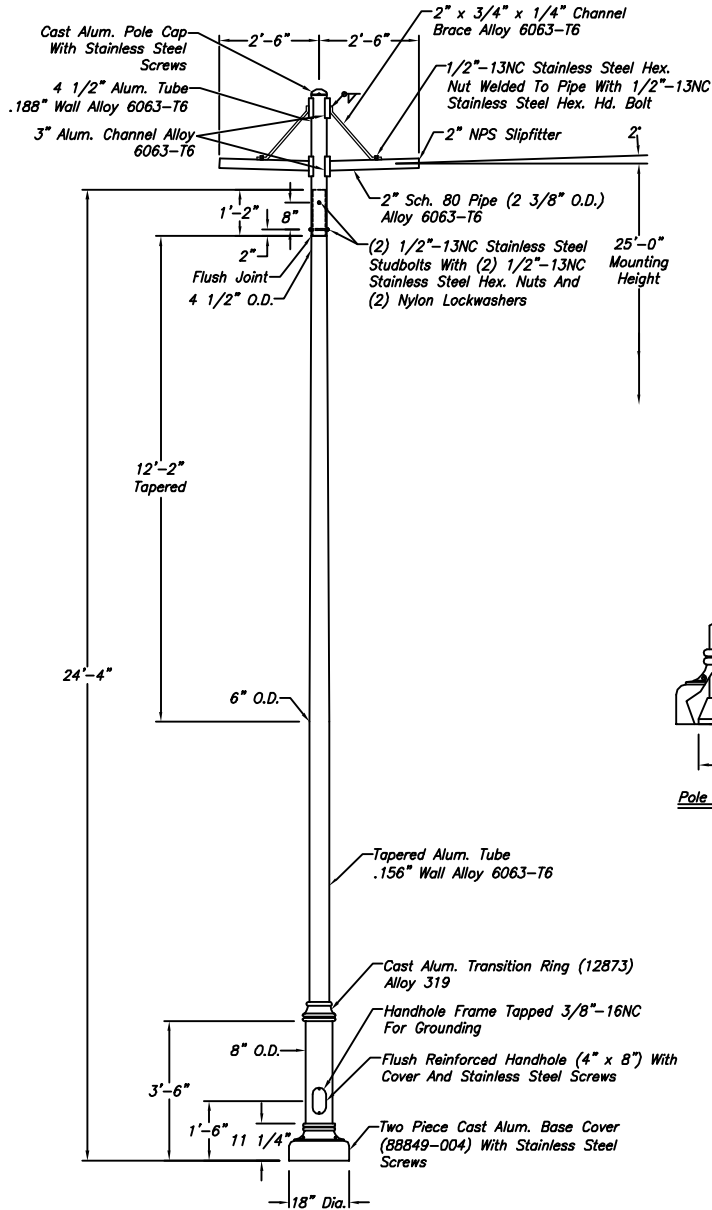

Pole Base Detail

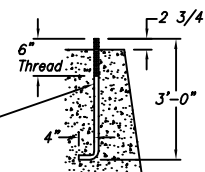
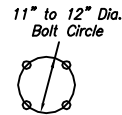

- (4) 1"-BNC Galv. Stl. Anchor Bolts, AASHTO M314-90 Grade 55, 10" Of Threaded End Galv. Per ASTM A153.
- (4) 1"-BNC Galv. Stl. Hex. Nuts
- (4) 1" Galv. Stl. Lockwashers
- (4) 1" Galv. Stl. Flatwashers

B16534

**WARNING: DO NOT INSTALL LIGHTING POLES WITHOUT LUMINAIRES**

NO.	REVISIONS	DATE

		TITLE TYPES B2/C1 LIGHTING POLES	
		CUSTOMER Vulcan Lakes, IL	
Abingdon, Va.		SCALE 3/2	DATE 03/18/2009
		BY TNB	DWG. NO.
		CHK'D	B16534

NOTES:

- 1) Shaft And Bracket Heat Treated To -T6 Temper After Welding.
- 2) Pole Meets 2001 AASHTO Specification For A 90 mph 3-Second Gust Wind Speed, 50 Year Design Life.
- 3) Design Conditions: Twin Luminaire Size Of 1.6 ft<sup>2</sup> E.P.A. (ea.) & 50 lbs. (ea.), 30" x 6' Banner (2.0 ft<sup>2</sup>) Centered At 19'-0".
- 4) Shaft And Arm To Be Powder Coated Gloss Black per HAPCO Specification 73737-466.

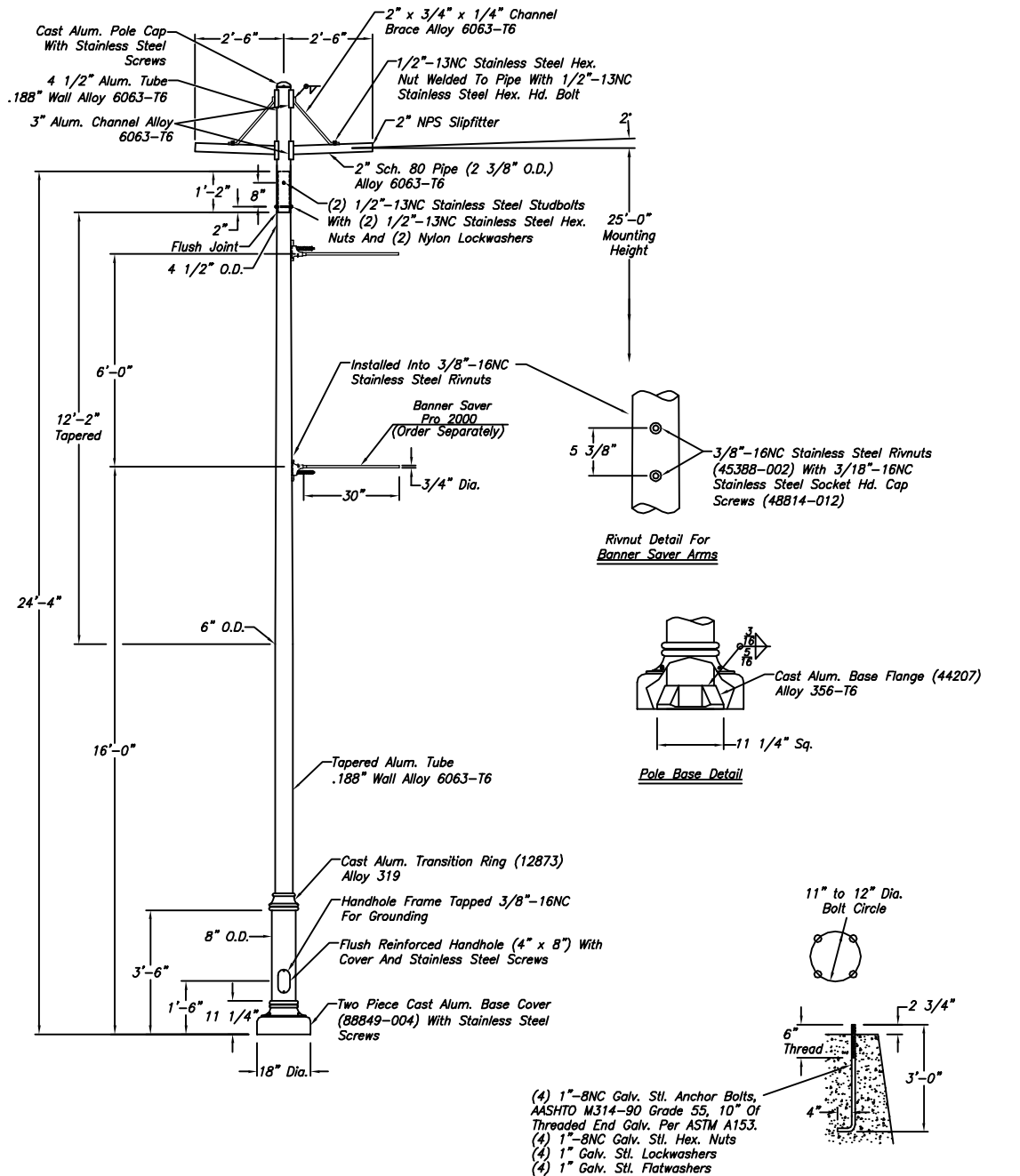

B16522

WARNING: DO NOT INSTALL LIGHTING POLES WITHOUT LUMINAIRES

NO.	REVISIONS	DATE

<b>hapco</b>		TITLE TYPES B3/C2 LIGHTING POLES	
Abingdon, Va.		CUSTOMER Vulcan Lakes, IL	
SCALE 32	DATE 03/18/2009	BY TNB	
CHK'D	DWG. NO. B16522		

NOTES:

- 1) Shaft And Bracket Heat Treated To -T6 Temper After Welding.
- 2) Pole Meets 2001 AASHTO Specification For A 90 mph 3-Second Gust Wind Speed, 50 Year Design Life.
- 3) Design Conditions: Luminaire Size Of 1.6 ft.<sup>2</sup> E.P.A. & 50 lbs., And Two Flower Baskets (By Others) 2 ft.<sup>2</sup> (ea.) and 75 lbs. (ea.) Located At 11'-0".
- 4) Shaft And Arm To Be Powder Coated Gloss Black per HAPCO Specification 73737-466.

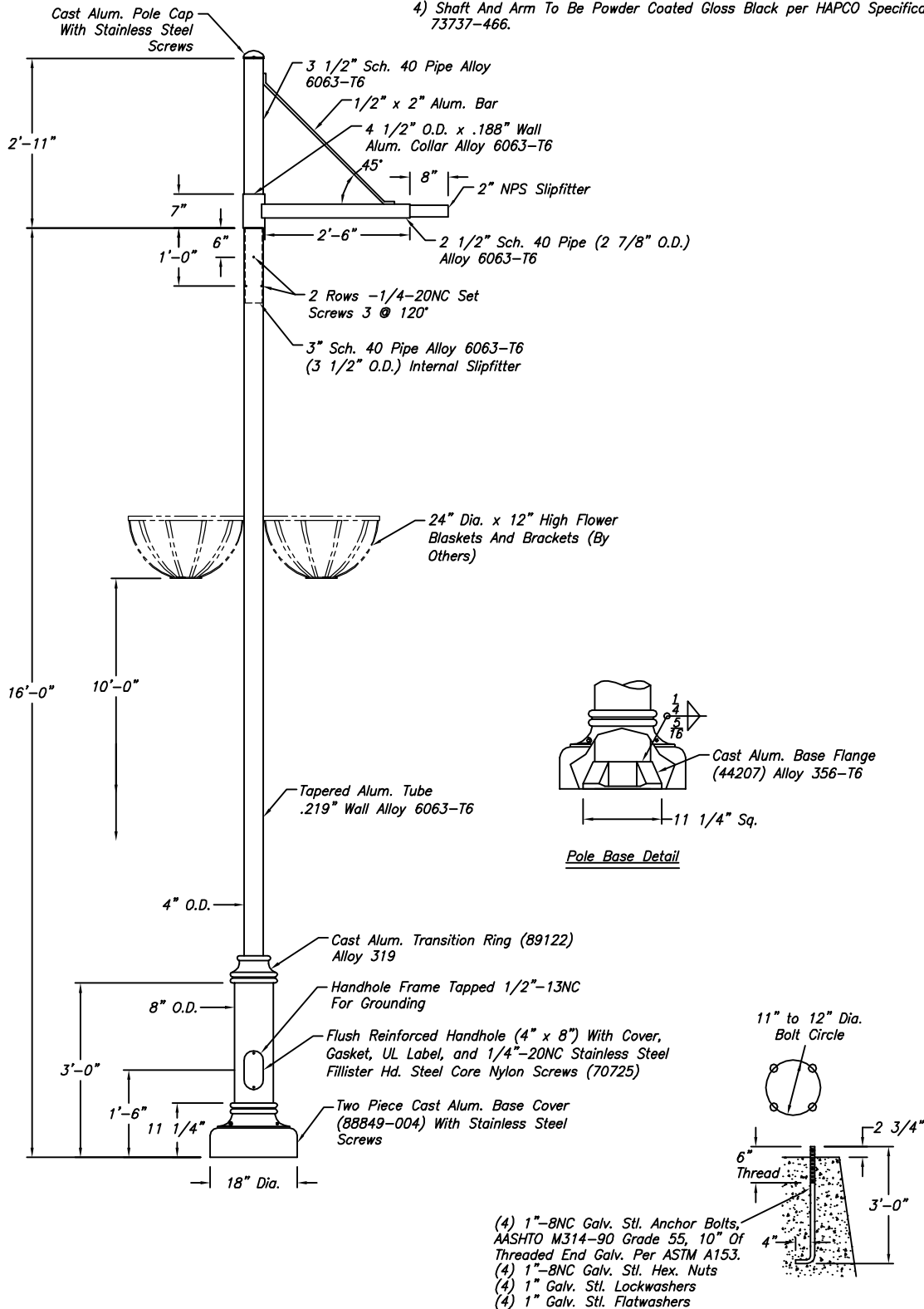

- (4) 1"-8NC Galv. Stl. Anchor Bolts, AASHTO M314-90 Grade 55, 10" Of Threaded End Galv. Per ASTM A153.
- (4) 1"-8NC Galv. Stl. Hex. Nuts
- (4) 1" Galv. Stl. Lockwashers
- (4) 1" Galv. Stl. Flatwashers

B16535

WARNING: DO NOT INSTALL LIGHTING POLES WITHOUT LUMINAIRES

NO.	REVISIONS	DATE

**hapco**  
Abingdon, Va.

TITLE TYPE D LIGHTING POLES  
CUSTOMER Vulcan Lakes, IL  
SCALE 16 DATE 03/20/2009  
BY TNB DWG. NO.  
CHK'D B16535

---

## Appendix VI – Street Light Design with Internal Cabinet





# Smart Fusion Pole

## Connecting the smart city

The Smart Fusion Pole, co-developed by American Tower and Signify (formerly Philips Lighting), have formed an alliance energy-efficient LED lighting with shared wireless infrastructure to solve network coverage and capacity challenges faced in cities.

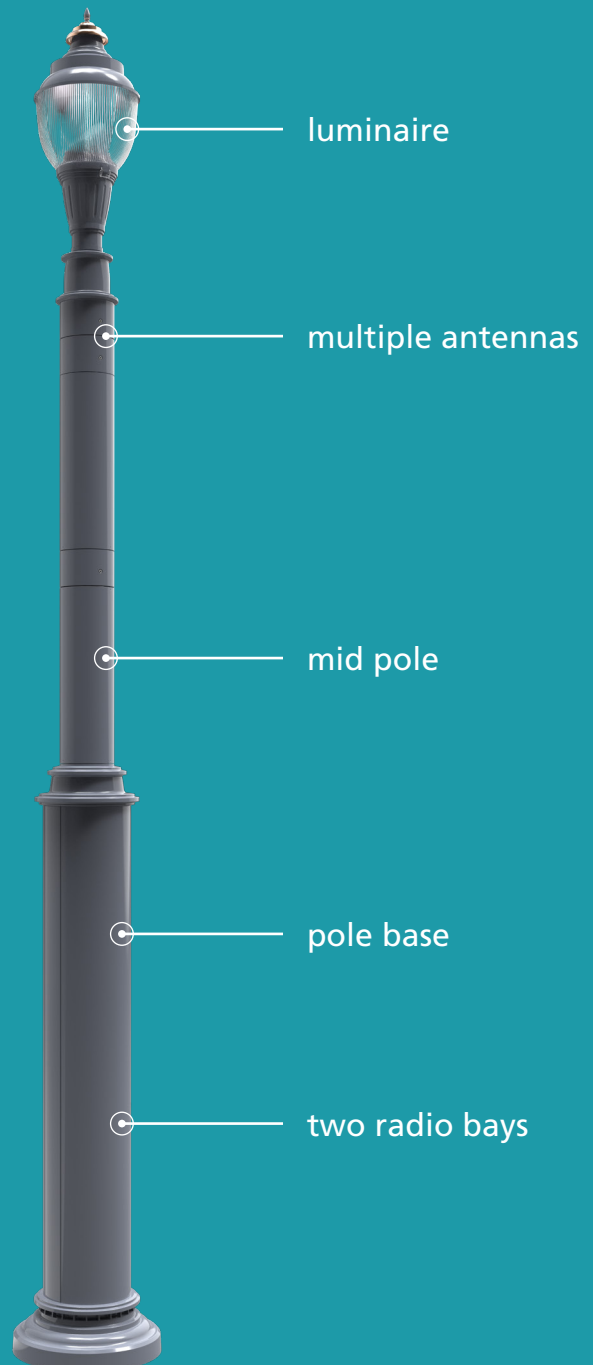

Learn more: [americantower.com/smartpoles](http://americantower.com/smartpoles) | [philips.com/smartpoles](http://philips.com/smartpoles)

# Smart Fusion Pole



## Prime locations

Access to hundreds of thousands of street-level sites in urban markets

## Large-scale deployment

Cluster permitting agreements with cities allow deployment of a large volume of sites at a time

## Fast and easy installation

Plug-and-play design provides ready access for mobile network operators

## Future ready access

Current and future radio hosting for easy transition to other technologies

## Aesthetic design

Variety of luminaires available and universal design to match any traditional or decorative street lights in the U.S.

## Supports multiple mobile network operators

Shared infrastructure to maximize scale and speed