



## #2012-25

# Lightning Lazer Tag

## Project Review for Planning and Zoning Commission

---

<b><u>Meeting Dates:</u></b>	April 18, 2012
<b><u>Requests:</u></b>	Land Use Variation from Article 2, Land Use of the Unified Development Ordinance to allow an amusement arcade as a permitted use in the “B-1” district
<b><u>Location:</u></b>	19 E. Berkshire, Units 4 & 5
<b><u>Acreage:</u></b>	≈ 0.97 acres (entire center) Tenant Space: 7,584 SF
<b><u>Existing Zoning:</u></b>	“B-1” Neighborhood Commercial
<b><u>Surrounding Properties:</u></b>	North: “B-2” General Commercial South: “R-2” Single-Family Residential (Canterbury Elementary) East: “B-1 PUD” Neighborhood Commercial PUD West: “R-2” Single-Family Residential
<b><u>Staff Contact:</u></b>	Latika Bhide (815.356.3615)

---

### **Background:**

- **Location:** 19 East Berkshire Drive. Tenant Suites 4 & 5 totaling 7,584 SF
- **Zoning:** “B-1” Neighborhood Commercial
- **Co-Tenants:** 7-Eleven, Summers Academy of Dance, Mansion Salon and Spa
- **Request:** Use Variation to allow an amusement arcade (lazer tag facility and arcade games) as a permitted use in the “B-1” Neighborhood Commercial district

### **Land Use Analysis:**

- **History:** In 1993, a special use permit for commercial recreation was approved for ‘Leaping Lizards’, an indoor recreational area for children. Subsequently, in 2002, a special use permit and variation were granted to allow a lazer tag facility at this location. In 2011, a land use variation to allow a used merchandise store at this location was approved.
- **Request:** The petitioner is requesting a land use variation to allow a lazer tag facility and arcade in an approximately 7,584-square-foot tenant space.
- **Permitted Uses:** Per Article 2, Land Use of the UDO, amusement arcades are permitted only in the “B-2” and “B-4” zoning districts.
- **Parking:** Per the UDO, 1 parking space is required for 250 square feet of gross floor area. Therefore, 30 parking spaces are required for this use. There are 48 parking spaces at this location. This center has a joint parking agreement with the owners of 35 Berkshire Drive

(located immediately to the east) that permit customers of both buildings to use the entire parking area. Therefore no parking problems are anticipated.

- Ordinance provisions: Per the UDO, amusement arcades must meet the following provisions :
  - a. Enclosed Facility: All activities shall take place within a wholly enclosed building.  
*The lazer tag and arcade games will be located entirely within the enclosed tenant space.*
  - b. Loitering: All persons waiting for service shall wait within the establishment. No exterior waiting or loitering shall be allowed.  
*The petitioner must advise their clients that exterior waiting or loitering is not permitted.*
  - c. Trash: Adequate trash and recycling facilities shall be maintained within the establishment for the use of customers.
  - d. License: If an amusement arcade license is not granted (or subsequently revoked) by the City Council, the limited use permit shall become null and void.  
*The petitioner has been apprised that a license is necessary for the installing the arcade games and the request will be presented to the City Council.*

**Findings of Fact:**

**USE VARIATION**

The granting of a Variation rests upon the applicant proving practical difficulty or hardship caused by the Zoning Ordinance requirements. It is the responsibility of the petitioner to prove hardship at the Planning and Zoning Commission public hearing.

No specific standards are spelled out in the Unified Development Ordinance for granting use variations. However, it is recommended that the Planning and Zoning Commission and City Council first determine and record its findings that the evidence justifies the conclusions that:

The property cannot be used for purposes permitted in the zoning district without the requested variance;

Meets  Does not meet

The proposed use would not alter the essential character of the area in which the property is located;

Meets  Does not meet

The proposed use will not reasonably diminish the value of adjacent property;

Meets  Does not meet

The proposed use will not unreasonably increase the congestion in the public streets or otherwise endanger public safety; and

Meets  Does not meet

The proposed use is in harmony with the general purpose and intents of the Unified Development Ordinance.

Meets  Does not meet

Where the evidence is not found to justify such conditions, that fact shall be reported to the City Council with a recommendation that the Variation be denied.

**Recommended Conditions:**

If a motion is made to recommend approval of the petitioner's request, the following conditions are suggested:

1. Approved plans, reflecting staff and advisory board recommendations, as approved by the City Council:
  - A. Development Application, received 3-30-12
  - B. Floor Plans, received 3-30-11
2. A use variation is hereby granted to allow an amusement arcade as a permitted use at this location.
3. The petitioner will advise their clients that exterior waiting or loitering is not permitted.
4. Adequate trash and recycling facilities shall be maintained within the establishment for the use of customers
5. The petitioner will contact the McHenry County Health Department to obtain any necessary permits if food is being served at this location.
6. Any signage proposed must meet the provisions of Article 4-1000, Signs of the UDO. Permits through the Building Division must be obtained for all signs.
7. The petitioner shall address all of the review comments and requirements of the Engineering and Building, Fire Rescue, Police, Public Works, and Planning and Economic Development Departments.

*L:\PLANNING AND ECONOMIC DEVELOPMENT\USER FOLDERS\LATIKA\_B\Reports\Lightning Lazer Tag.doc*

**City of Crystal Lake  
Development Application**

Office Use Only **25 2012**  
File # \_\_\_\_\_

Project Title: Lightning Laser Tag

**RECEIVED**  
MAR 30 2012  
BY: \_\_\_\_\_

**Action Requested**

- |   |  |
|---|--|
| <input type="checkbox"/> Annexation                   | <input type="checkbox"/> Preliminary PUD                 |
| <input type="checkbox"/> Comprehensive Plan Amendment | <input type="checkbox"/> Preliminary Plat of Subdivision |
| <input type="checkbox"/> Conceptual PUD Review        | <input type="checkbox"/> Rezoning                        |
| <input type="checkbox"/> Final PUD                    | <input type="checkbox"/> Special Use Permit              |
| <input type="checkbox"/> Final PUD Amendment          | <input checked="" type="checkbox"/> Variation            |
| <input type="checkbox"/> Final Plat of Subdivision    | <input type="checkbox"/> Other                           |

**Petitioner Information**

Name: Justin Christopherson  
Address: 2 Banbury Court  
Lake in the Hills, IL  
Phone: (847) 575-7939  
Fax: \_\_\_\_\_  
E-mail: phyrman13@gmail.com

**Owner Information (if different)**

Name: Andy Kostas  
Address: \_\_\_\_\_  
Phone: \_\_\_\_\_  
Fax: \_\_\_\_\_  
E-mail: \_\_\_\_\_

**Property Information**

Project Description: Use Variation for a Laser Tag  
Facility in a "B-1" zoning district

Project Address/Location: 19 E. Berkshire, Units 4+5

PIN Number(s): \_\_\_\_\_

**Development Team**

Please include address, phone, fax and e-mail

Developer: \_\_\_\_\_

Architect: \_\_\_\_\_

Attorney: \_\_\_\_\_

Engineer: \_\_\_\_\_

Landscape Architect: \_\_\_\_\_

Planner: \_\_\_\_\_

Surveyor: \_\_\_\_\_

Other: \_\_\_\_\_

**Signatures**



3/23/12

PETITIONER: Print and Sign name (if different from owner)

Date

As owner of the property in question, I hereby authorize the seeking of the above requested action.

OWNER: Print and Sign name

Date

NOTE: If the property is held in trust, the trust officer must sign this petition as owner. In addition, the trust officer must provide a letter that names all beneficiaries of the trust.

**PUBLIC NOTICE**

**BEFORE THE PLANNING AND  
ZONING COMMISSION  
OF THE CITY OF CRYSTAL LAKE,  
MCHENRY COUNTY, ILLINOIS**

IN THE MATTER OF THE APPLI-  
CATION OF Justin Christophersen

**LEGAL NOTICE**

Notice is hereby given in compli-  
ance with the Unified Development  
Ordinance of the City of Crystal  
Lake, Illinois that a public hearing  
will be held before the Planning  
and Zoning Commission of the City  
of Crystal Lake upon the applica-  
tion of Justin Christophersen on be-  
half of Lightning Lazer Tag, relating  
to the following described real es-  
tate commonly known as 19E,  
Berkshire, Units 4 and 5, Crystal  
Lake, Illinois 60014, PIN: 19-08-  
426-006.

This application is filed for the  
purposes of seeking a Use Variation  
from Article 2, Land Use of the Uni-  
fied Development Ordinance to al-  
low a Amusement Arcade (Indoor  
Lazer Tag) within a building locat-  
ed in a "B-1" neighborhood busi-  
ness zoning district at the above-  
mentioned location. This request in-  
cludes variations that may be nec-  
essary to allow the project as pre-  
sented. Plans for this project can be  
viewed at the City of Crystal Lake  
Community Development Depart-  
ment at City Hall.

A public hearing before the Plan-  
ning and Zoning Commission on  
the request will be held at 7:30  
p.m. on Wednesday, April 18,  
2012 at the Crystal Lake City Hall,  
100 West Woodstock Street, at  
which time and place any person  
determining to be heard may be  
present.

Tom Hayden, Chairperson  
Planning and Zoning Commission  
City of Crystal Lake  
(Published in the Northwest Herald  
April 3, 2012)

RECEIVED  
MAR 30 2012  
BY:

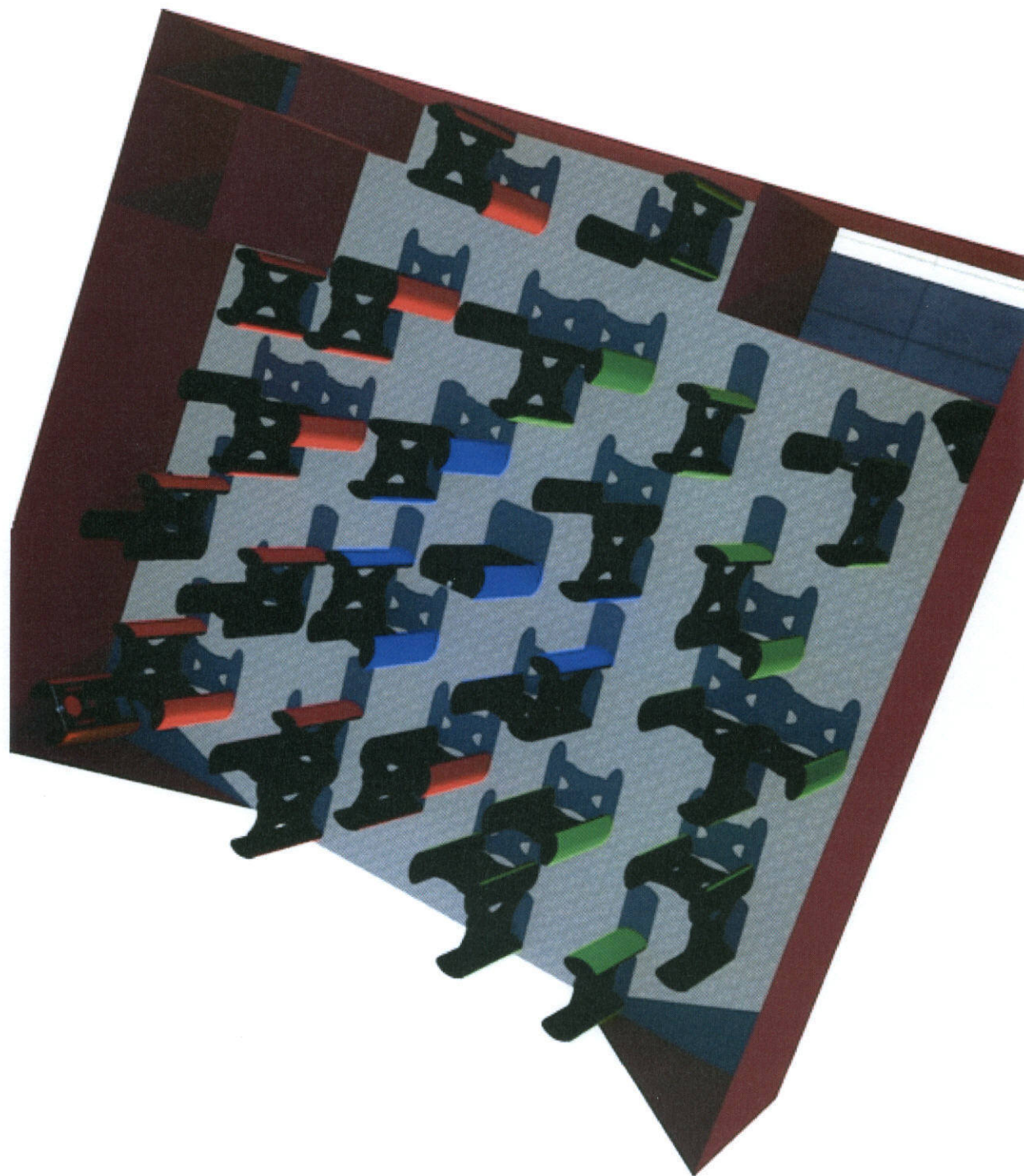

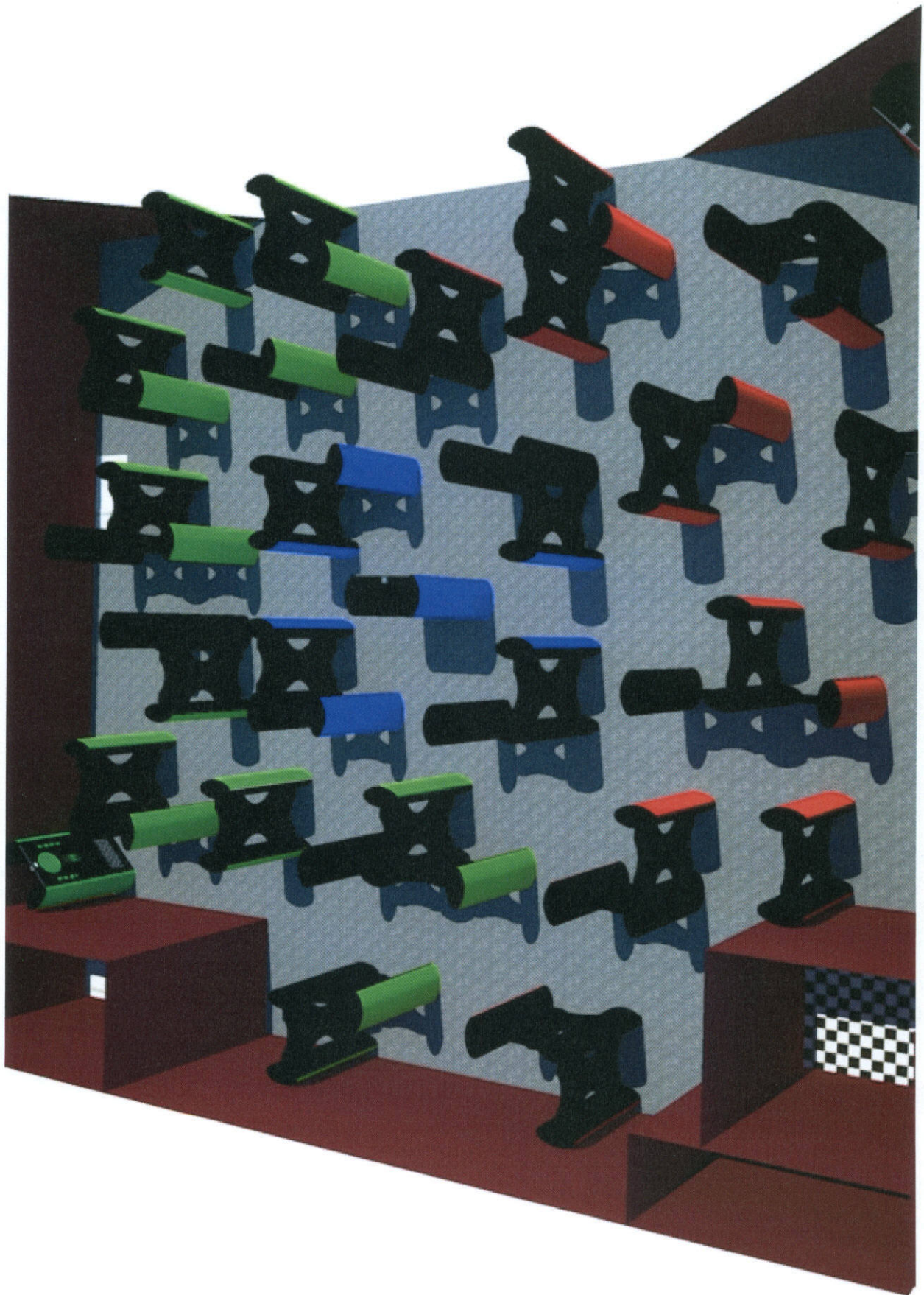



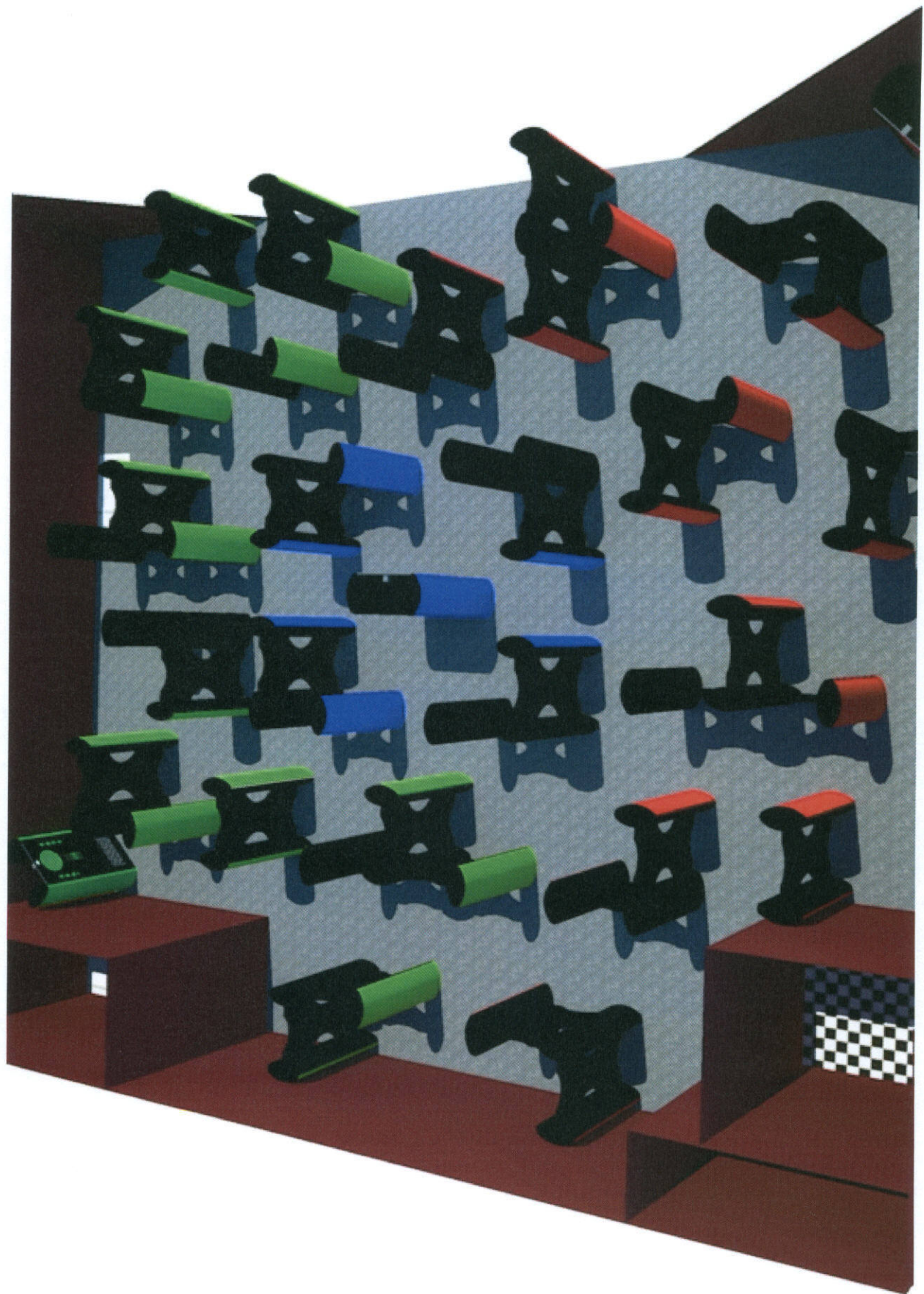



25 2012

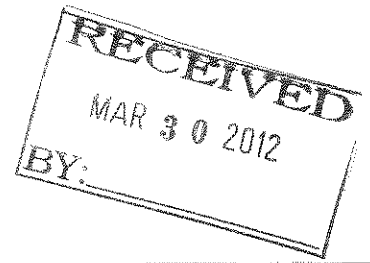

7927A Coronet Road, Edmonton, Alberta, Canada T6E 4N7  
Tel: (780) 496-9058 Fax: (780) 496-9059  
E-Mail: LaZer@LaZerRunner.com Website: www.LaZerRunner.com

# BATTLE STATION

# DATA SHEETS

## COLUMN HARDWARE

### L-BRACKET

- For securing base, Fluorescent & Black Column side panels.

(5)

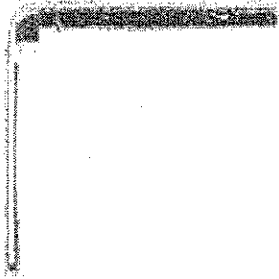

### FENDER WASER

- Base washer with 3.5" Deck Screw

(1)

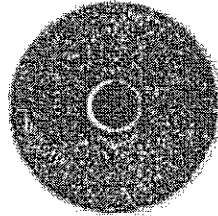

### 3.5" FLOORING SCREW

- Attach Fluorescent & Black Panels To the 2 x 4 frame of the column.

(4)



### 4" PIN ANCHOR

- Attach 2 x 4 to the Base plate into concrete

(1)



### 1/4" LOCK WASHER

(3)



### 3.5" DECK SCREW

- To attach Base plate to the 2 x 4

(4)



### 1/4" NUT

(2)



### WAFER SCREW

- To attach wall panels to the column

(7)



### 1" MACHINE SCREW

(1)



### 2.5" PIN ANCHOR

(1)



CONNECTING TO THE FLOOR

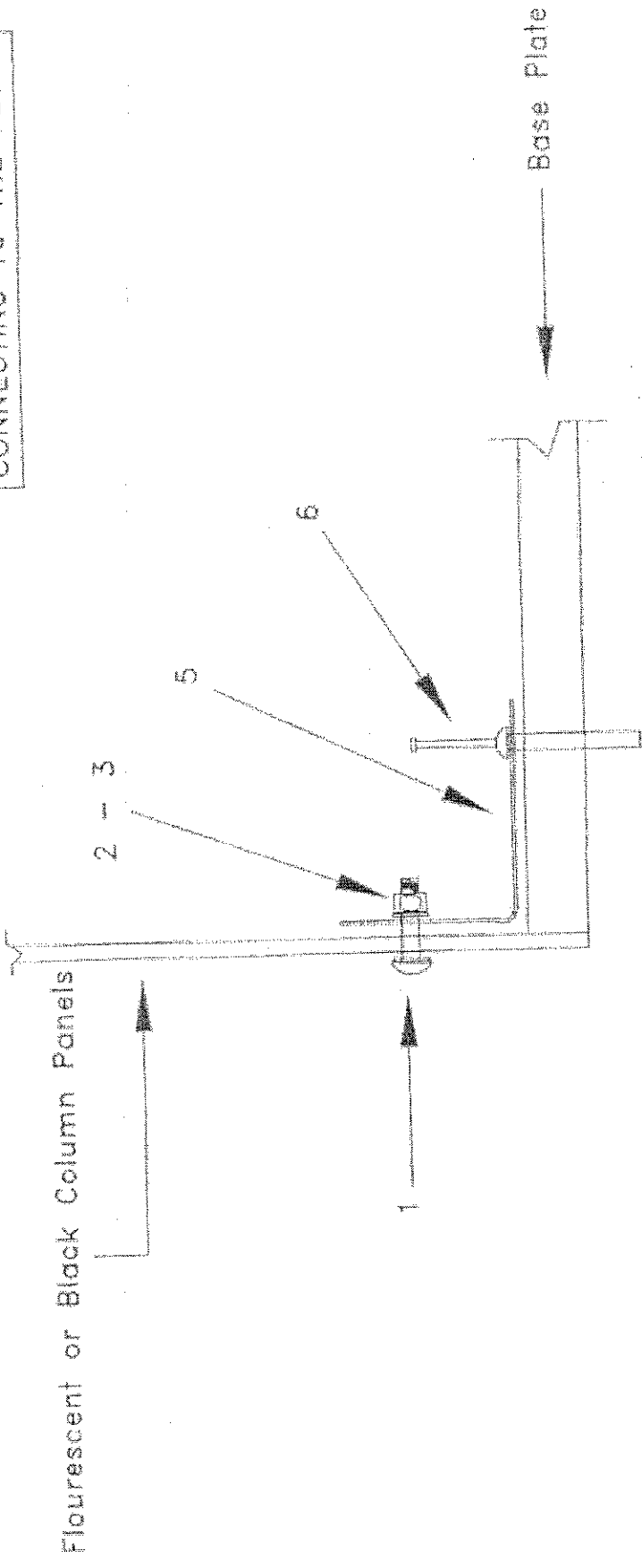

# BASE PLATE

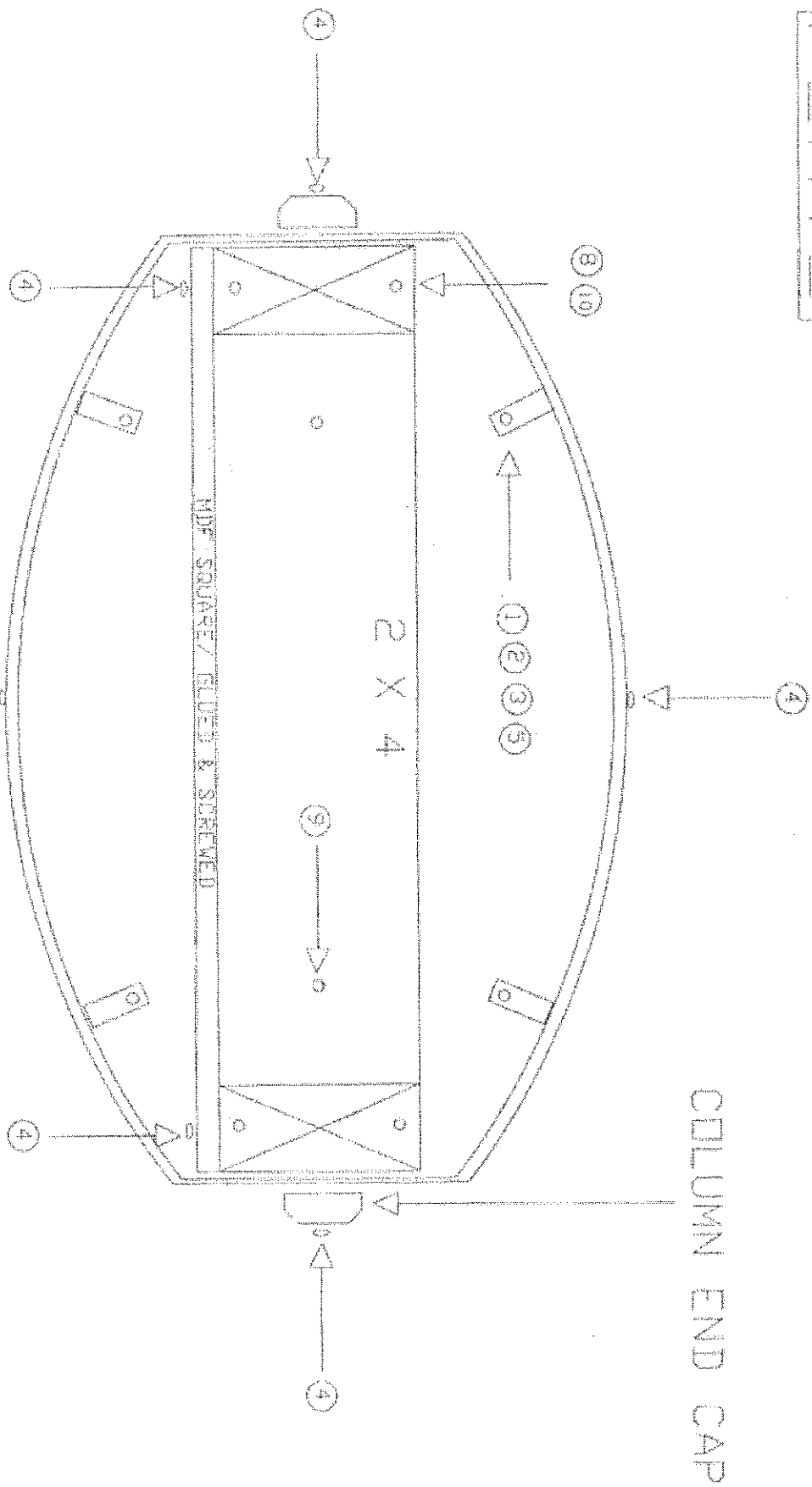

# ARCHWAY ELEVATION

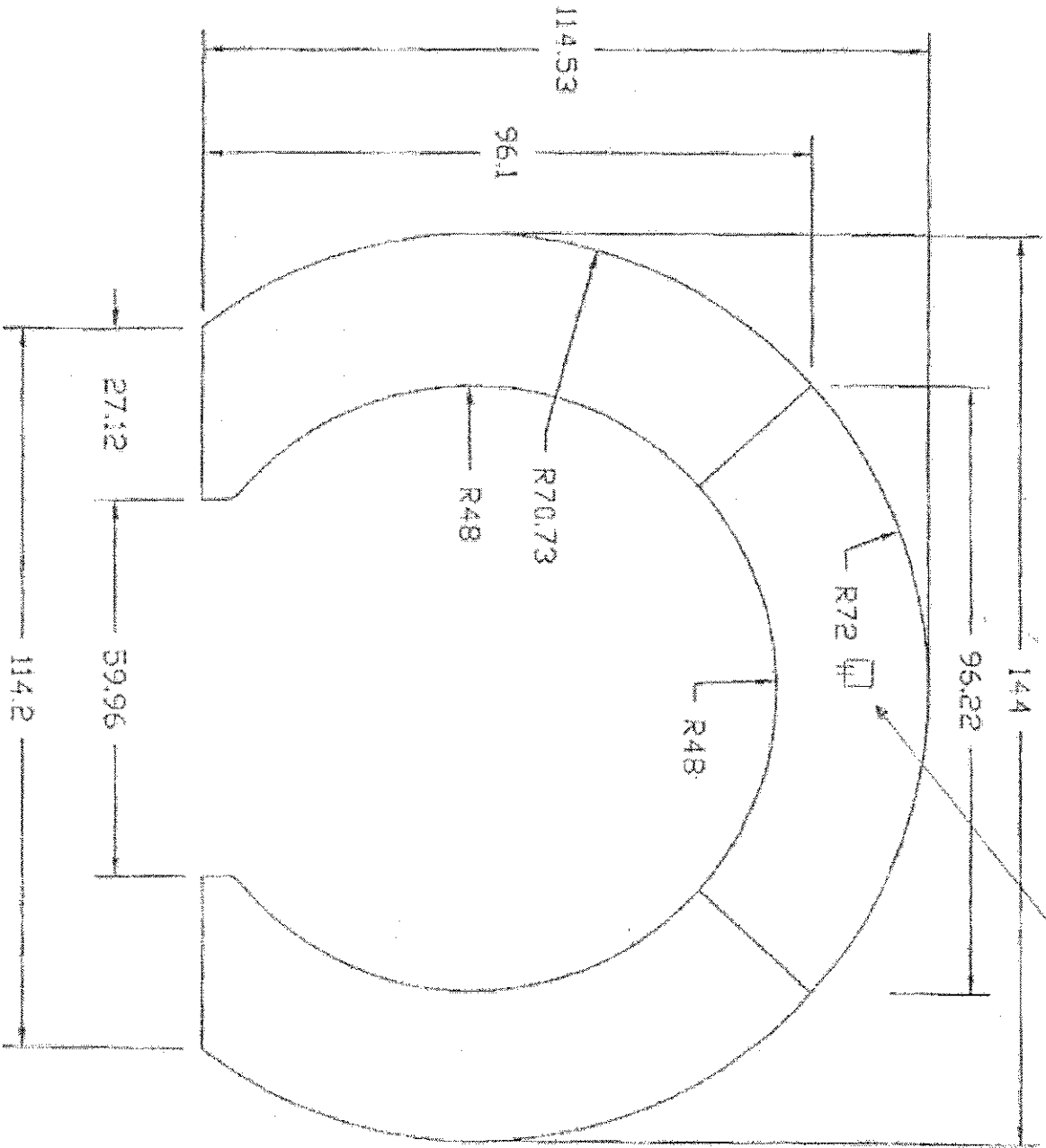

Power location



2927A Coronet Road, Edmonton, Alberta, Canada T6E 4N7  
Tel: (780) 466-9058 Fax: (780) 466-5050  
E-Mail: LaZer@LaZerRunner.com Website: www.LaZerRunner.com

March 9, 2005

### CERTIFICATE OF COMPLIANCE

To Whom It May Concern:

This letter is to confirm that the lasers used in the 'LaZer Runner Laser tag System' are certified to be in compliance with United States Safety Standards for laser products, Class II (21 CFR 1040.10). LaZer Runner's power outputs for Pulsated Wave (PW) lasers are operating in the visible range between .8 mW - 1 mW.

Yours truly,

A handwritten signature in black ink, appearing to read "Ping Shi". The signature is fluid and cursive, written over a white background.

Ping Shi  
Engineer Technologist  
LaZer Runner Laser Tag Systems

# Orion

## ARENA BOARD® VIRGIN HDPE COPOLYMER

### Features:

- High gloss HDPE for aesthetic applications
- Custom colors can be matched consistently
- Impervious to most chemicals and solvents
- Class one / Class A flame spread rating (ASTM D3806 - 90a, available upon request)
- Canadian Food Inspection Agency approval to use in Federally inspected facilities
- Weldable for custom fabrication applications

### Applications:

- Indoor hockey rinks
- Custom plastic fabrication
- Commercial, industrial and agricultural interior applications

### Description:

ARENA BOARD is a extruded virgin HDPE copolymer. It is designed for interior applications that require a product with a high gloss finish, consistent color and a range of gauges and dimensions.

### Product Dimensions:

Gauge: .090", .110", .220", .375", .500" Width: 48" to 60" Length: 96", 120", roll stock available  
 (Note: some heavy gauge sheet not available in 60" sheet; some custom dimensions available with special order, call for details.)

### Colors:

White,, Black, Grey, Arena Red, Arena Blue, Arena Gold, Canary yellow, Dark forest green.  
 (Note: Custom colors available with minimum order.)

### Product Properties:

ASTM (1)

Typical Values (2)

Mechanical	ASTM (1)	English Units	SI Units
Tensile Strength @ Yield	D638	3400 psi	23 Mpa
Elongation @ break	D638	660%	660%
Flexural modulus	D790	153,000 psi	1150 Mpa
Tensile impact strength	D1827	150 ft-lb/in <sup>2</sup>	32 J/cm <sup>2</sup>
ESCR, F50 (a)	D1683	> 100 hr	> 100 hr
Brittleness temperature	D746	< -60 degrees C	< -64 degrees F

\*ESCR (a) 100% Impact

Product properties represent average laboratory values and are intended as a guide line. Final testing is the responsibility of the end user.

MANUFACTURERS OF EXTRUDED SHEET PRODUCTS



ORION PLASTICS INC.

TABLE 1

SMALL SCALE EVALUATION OF  
POLYETHYLENE SHEET MATERIALS

SAMPLE DESCRIPTION	OUR REF. #	FLAME SPREAD RATING*
0.375" White Arena	CL00-114.1	21.7*
0.500" White Arena	CL00-114.2	22.0*
0.375" White Tough	CL00-114.3	24.3*

\*NOTE: According to ASTM D3806, the average of the five runs is reported as the flame spread rating.

ALBERTA  
RESEARCH  
COUNCIL



Edmonton  
Mailing/Street  
282, Kivik Clark Road  
Edmonton, Alberta  
Canada T6N 1E4  
Tel (780) 450-5111  
Fax (780) 450-5333

Calgary  
Mailing/Street  
3008 - 33 St. N.W.  
Calgary, Alberta  
Canada T2L 2A6  
Tel (403) 210-5222  
Fax (403) 210-5360

Devon  
Mailing/Street  
100 Patch Drive  
Suite A100  
Devon, Alberta  
Canada T9C 1A8  
Tel (780) 450-5111  
Fax (780) 297-5923

Vegreville  
Mailing  
PO Box 4000  
Vegreville, Alberta  
Canada T9C 1T4  
Street  
Highway 16A & 75 Street  
Vegreville, Alberta  
Tel (780) 632-4271  
Fax (780) 632-4379

April 30, 1999

Orion Plastics Inc.

Attention: Greg Makar

Dear Greg,

Re: Evaluation of Polyethylene Sheet Materials  
Our reference #CL99-51

Please find enclosed the results for the evaluation of polyethylene sheet materials we received from you on April 23, 1999. Five test specimens from each material type were tested in accordance with ASTM D3886-90a (Small Scale Evaluation of Fire-Retardant Paints (2-Foot Tunnel Method)) using red oak as the flame spread rated standard (red oak FSR-100). All samples and calibration specimens were conditioned at test parameters outlined in the test method excepting the conditioning period of the specimens which was 7 days.

The results for the evaluations are included in the attached table (Table 1). We will hold the samples for 60 days in case you want the test specimens returned to you. This report should only be reproduced in full and with the permission of the Alberta Research Council.

If you have any questions, please do not hesitate to call me at (780) 450-5433.

J. J. J.

Sincerely,

Jim Melnychuk  
Advanced Materials Group\*

encl.  
JM



CGSB Laboratory Accreditation Program and accredited by the Standards Council of Canada as a Testing Organization for specific registered tests.

801

ALBERTA  
RESEARCH  
COUNCIL



Edmonton  
Herby Street  
250 West Clark Road  
Edmonton, Alberta  
Canada T6N 1G4  
Tel (780) 450-5111  
Fax (780) 450-5111

Calgary  
Maitland Street  
3606 - 13 St. N.W.  
Calgary, Alberta  
Canada T2A 2A6  
Tel (403) 210-5222  
Fax (403) 210-5200

Devon  
Maitland Street  
101 Park Drive  
Suite A129  
Devon, Alberta  
Canada T9G 1A8  
Tel (780) 450-5271  
Fax (780) 767-5285

Wegreville  
Maitland  
PO Box 4000  
Wegreville, Alberta  
Canada T9C 1Y4  
Street  
1101 14A & 75 Street  
Wegreville, Alberta  
Tel (780) 632-8221  
Fax (780) 632-8179

December 20, 2000

Orion Plastics Inc.

Attention: Greg Makar

Dear Greg,

Re: Evaluation of Polymer Sheet Materials.  
Our reference #CL00-114. File #00-279.

In reference to your inquiry regarding the flame spread rating evaluations that the Alberta Research Council has been performing for you. I have located some information that you may be interested in.

In your observations of recent results compared to older results, you mentioned that you noticed slightly higher flame spread rating values for the newer and thicker arena board samples. The difference in these results is very small considering the minimum measurement of flame spread travel during testing of the samples. Indeed, the smallest possible difference in flame spread measurement results is a change of 4 to 5 units in the final results.

The ASTM D3806-90a test standard indicates that the repeatability of results for identical materials is 4.8 units. The results for your materials, even though they are tested at different thicknesses, would be acceptable as a variation of results for identical materials.

The most important factor to keep in mind is that all results below a flame spread rating of 25, when tested in accordance with ASTM D3806-90a, result in a class 1 or class A rating, which is the highest rating that can be determined using this method.

If you have any questions, please do not hesitate to call me at (780) 450-5438.

Sincerely,

Jim Melnichuk  
Advanced Materials Group

JM

# Orion

06/07/99

Overview ASTM D3806-90a  
Small Scale Evaluation of Fire-Retardant Paints

Sample size: 4" x 24" (note sample thickness on result sheet)

Burn time: 4 minutes

Burn temp: 1055 degrees Celsius to 1100 degrees Celsius

Flame placement: 1/8" from bottom edge of sample

Note: Results are based on the percentage of the sheet burned, and are in comparison to Red oak as the flame spread standard at 100% burn. (Red oak ESR=100)

*Copies of entire test method are available upon request.*

The information supplied is believed to be accurate and reliable, but no representations, guarantees, or warranties are expressed or implied. Results are based on laboratory work and do not necessarily indicate product performance. Full-scale testing and end product performance is the responsibility of the purchaser.

MANUFACTURERS OF EXTRUDED SHEET PRODUCTS

ALBERTA  
RESEARCH  
COUNCIL



Edmonton  
Manning Street  
250 Karl Clark Road  
Edmonton, Alberta  
Canada T6N 1E4  
Tel (780) 450-5000  
Fax (780) 450-5033

Calgary  
Manning Street  
3608 - 33 St. N.W.  
Calgary, Alberta  
Canada T2L 2A6  
Tel (403) 210-5222  
Fax (403) 210-5280

Devon  
Manning Street  
108 Peach Drive  
Suite A129  
Devon, Alberta  
Canada T9G 1A8  
Tel (780) 450-8151  
Fax (780) 987-5250

Vegreville  
Manning  
PO Box 4099  
Vegreville, Alberta  
Canada T9C 1T1  
Street  
Elroy 16th & 75 Street  
Vegreville, Alberta  
Tel (780) 632-6211  
Fax (780) 632-8179

December 8, 2000

Orion Plastics Inc.

Attention: Greg Makar

Dear Greg,

Re: Evaluation of Polymer Sheet Materials.  
Our reference #CL00-114, File #00-279.

Please find enclosed the results for the evaluation of polymer sheet materials we received November 27, 2000. Five test specimens from each material type were tested in accordance with ASTM D3800-90a (Small Scale Evaluation of Fire-Retardant Paints (2-Foot Tunnel Method)) using red oak as the flame spread rated standard (red oak FSR=100). All samples and calibration specimens were conditioned at test parameters outlined in the test method.

The results for the evaluations are included in the attached table (Table 1). We will hold the samples for 60 days in case you want the test specimens returned to you.

If you have any questions, please do not hesitate to call me at (780) 450-5435.

Sincerely,

Jim Melnichuk  
Advanced Materials Group

encl.  
JM

# ORION PLASTICS INC.

TABLE 1

## SMALL SCALE EVALUATION OF POLYETHYLENE SHEET MATERIALS

SAMPLE DESCRIPTION	OUR REF. #	FLAME SPREAD RATING*
0.110 Arena Board HDPE	CL99-51.1	42.8*
0.220 Arena Board HDPE	CL99-51.2	17.5*
0.220 Tough Sheet	CL99-51.3	17.5*
0.200 H1M W Re grind	CL99-51.4	21.2*

\*NOTE: According to ASTM D3806, the average of the five runs is reported as the flame spread rating.

**CRYSTAL LAKE ZONING BOARD OF APPEALS  
WEDNESDAY, APRIL 3, 2002**

Acting Chair Ehlert called the meeting to order at 7:30 p.m.

Mr. Ehlert asked the people in attendance to rise to say the Pledge of Allegiance. He led those in attendance in the Pledge.

On roll call, members Granell, Jouron, Nering, Skluzacek, and Ehlert were present. Members Ferrentino and Hayden were absent.

James Richter, Planner, was present from Staff.

**2002-17 LAZER EXTREME – 19 E. BERKSHIRE DR.** – PUBLIC HEARING

Special Use Permit for a Commercial Recreational Use  
Zoning Variation from Section 5.3-5.4 for required parking, to allow 28 parking spaces for the proposed use, in lieu of the required 29 parking spaces, a Variation of 1 parking space

Mr. Ehlert stated the fees have been paid, and the sign has been posted. He said the surrounding property owners have been notified and the Certificate of Publication is in the file. Mr. Hayden waived the reading of the legal notice with no objection.

Dave and Ann Covalt, owners, Ann Hughes with Hughes Signs, and Mark Elmore, architect, were present to represent the petition. Mr. Covalt said they are purchasing the former Lazer Storm and they would like to open the use in the former Leaping Lizards space at 19 Berkshire Drive. They will have lazer tag and a video arcade. He described the layout of the building. Mr. Covalt said the building would be sprinklered. He said the business will be closed on Monday, and will be open 1 p.m. to 10 p.m. Tuesday through Thursday, 11 a.m. to 11 p.m. Friday and Saturday, and noon to 8 p.m. on Sunday. These times are tentative. Mr. Covalt said they agree with the conditions and are currently in discussion with the landlord concerning three of them.

Mr. Jouron asked about the parking. He asked where the employees would park. Mr. Richter said they could use any of the parking just like anyone else. Mr. Jouron prefers that they park away from the building. Mrs. Granell said that would go for all of the business there and that would be difficult to get them to ok that. She asked if they talked with the adjacent businesses regarding this use and sufficient parking. Mr. Covalt said they haven't heard any negative feedback from the businesses. He said there would be a lot of drop-off business.

Mike Dierkes, owner of Lazer Storm, said they have 22 parking spaces at the other site and rarely had a full lot. Most of their business was drop-off. Mrs. Granell asked what their maximum occupancy was. Mr. Dierkes said he was not sure but there was never more than 100 people in the place at one time.

Mrs. Granell asked if the neighbors are aware of the hours of operation. Mr. Covalt said the operation times are not etched in stone. Mr. Jouron said the White Hen is open 24 hours. Mr. Elmore said there would not be any light problem from the building.

Mr. Jouron asked if the other lot for the Laundromat, etc. is a separate lot. Mr. Richter said yes. Mr. Jouron said he has no problem with the use but feels there will be a lot of traffic from it.

Mrs. Granell asked about the number of employees there will have. Mr. Covalt said there would be 1 to 2 full time employees and 6 to 8 part time. Mr. Dierkes said they did not have more than 6 employees at one time and that was on Saturday. Mrs. Granell asked if the employees could park away from the building. Mr. Covalt said yes.

There was no one else in the public who wished to speak on this petition. The public hearing was closed at this time.

Mrs. Granell moved to approve the Special Use Permit for a Commercial Recreation Use and Zoning Variation from Section 5.3-5.4 for required parking, to allow 28 parking spaces for the proposed use, in lieu of the required 29 parking spaces, a Variation of 1 parking space for Lazer Extreme at 19 E. Berkshire Drive with the following conditions:

1. Plans approved by the City Council, with changes reflecting staff and advisory board recommendations:
  - A. Application (Lazer Extreme, LLC, received 03/01/02).
  - B. Plat of Survey (Chicagoland Survey Co., received 03/01/02).
  - C. Floor Plan Set (Elmore and Associates, dated 02/21/02).
  - D. Wall Sign Elevation (Hughes Sign Co., dated 03/06/02).
2. Floor Plan Set (Elmore and Associates, dated 02/21/02).
  - A. Provide a more detailed layout for the arcade and the laser tag arena to the Planning Department in order to ensure that the intensity of the use does not increase beyond a level than what is intended by this Special Use Permit.
3. If the petitioner intensifies the use of the facility, which in turn, requires more parking than is provided, then the petitioner must seek a Special Use Permit Amendment and additional Variations for parking.
4. The petitioner shall work with the owner to paint and/or maintain the bleached and faded areas on the east (front) mansard roof to match the balance of the shopping center.
5. The petitioner shall work with the owner to repair or replace the existing fence along the south property line.
6. The petitioner shall work with the owner to re-stripe all parking spaces within the shopping center. Two handicapped parking spaces must be provided.
7. All trash and litter along the south and west sides of the shopping center must be cleaned up prior to occupancy.
8. The following Zoning Ordinance Variation is hereby granted:
  - A. Section 5.3-5.4 for required parking, to allow 28 parking spaces for the proposed use, in lieu of the required 29 parking spaces, a Variation of 1 parking space.
9. The petitioner shall address all of the review comments of the Building, Fire/Rescue, Police and Planning Departments.
10. Employee parking is restricted to the north end of the parking lot.

Mr. Jouron seconded the motion. On roll call, all members voted aye. Motion passed.



**Special Use Permit – Lazer Extreme**

The Council considered a request from Lazer Extreme of Crystal Lake, LLC for approval of a Special Use Permit for the property located at 19 East Berkshire Drive in order to allow for a commercial recreational use. The Council also considered a requested variation from the Zoning Ordinance in order to allow 28 parking spaces for the proposed use, in lieu of the required 29 parking spaces. Attorney Harry Stinespring and business owner Dave Covalt were present to represent the matter.

Councilwoman Brady Mueller stated that she did not feel that employee parking restrictions should be imposed on this business since none of the other businesses in the shopping center had such restrictions. Councilwoman Ferguson agreed. Councilwoman Brady Mueller moved to approve the recommendations of the Zoning Board of Appeals except #10 regarding employee parking restrictions, approve the requested Special Use Permit and the requested zoning variation, and to adopt an ordinance to be published in pamphlet form by the authority of the Mayor and City Council authorizing the issuance of a Special Use Permit and approving the zoning variation for Lazer Extreme of Crystal Lake, LLC. Councilwoman Ferguson seconded the motion. On roll call, all voted aye. Motion passed.

**Preliminary PUD, Special Use Permit and Zoning Variations – Culver's Restaurant**

The Council considered a request from Culver's of Crystal Lake for approval of a proposed Preliminary Planned Unit Development, Special Use Permit and Zoning Variations to allow for a Culver's Restaurant with outside seating, a drive-thru facility, and to allow 9 ft. x 17 ft. parking spaces instead of the required 9 ft. x 19 ft.; to allow 5 ft. along the east perimeter instead the required 15 ft. minimum wide landscape area for perimeters of parking lots abutting public rights-of-way; and to allow a 2 ft. wide landscape area for perimeters of parking lots not abutting public rights-of-way instead of the required 8 ft. minimum. Attorney Mark Saladin and Robert Bach of R. Bach Construction were present to represent the matter.

Mr. Saladin noted that the Zoning Board of Appeals had not objected to the blue metal roof. Mayor Shepley asked if they still wished to have neon around the building. Mr. Saladin stated that they were only requesting to have a neon accent on the front gable facing Pingree Road.

Mayor Shepley asked if anyone in the audience wished to speak on the matter. No one wished to speak.

Councilwoman Ferguson stated that she would prefer to not defer installation of sidewalks since she felt that there would be pedestrian traffic with the hotels, restaurants and theater. Councilwoman Ferguson asked about sidewalks on Tracy Trail, a privately owned road. Mr. Saladin stated that he understood that sidewalks would be installed on the north side of Tracy Trail only. Councilman Dawson agreed with Councilwoman Ferguson, stated that he felt that sidewalks should be installed within a one year time period after Pingree Road is improved and

AN ORDINANCE GRANTING A SPECIAL USE PERMIT  
AND A VARIATION  
AT 19 E. BERKSHIRE DRIVE

WHEREAS, pursuant to the terms of a Petition (File #2002-17) before the Crystal Lake Zoning Board of Appeals, the Petitioner has requested the issuance of a Special Use Permit to allow a Commercial Recreational Use and Zoning Variation from Section 5.3-5.4 for required parking, to allow 28 parking spaces for the proposed use, in lieu of the required 29 parking spaces, a variation of 1 parking space for the property located at 19 E. Berkshire Drive; and

WHEREAS, it is in the best interests of the CITY OF CRYSTAL LAKE that the Special Use Permit and Variation be issued as requested in said Petition.

BE IT ORDAINED BY THE MAYOR AND CITY COUNCIL OF THE CITY OF CRYSTAL LAKE, McHENRY COUNTY, ILLINOIS, as follows:

Section I: That a Special Use Permit be issued to allow a Commercial Recreational Use and Zoning Variation from Section 5.3-5.4 for required parking, to allow 28 parking spaces for the proposed use, in lieu of the required 29 parking spaces, a variation of 1 parking space for the property legally described as follows:

PARCEL 1: Lot 1 in Berkshire Drive re-subdivision, being a subdivision of part of Lots 14 and 15 in Plat of Farms at Crystal Lake, being a subdivision of part of Section 8, Township 43 North, Range 8 East of the Third Principal Meridian, according to the plat thereof recorded December 20, 1976 as Document No. 682403, in McHenry County, Illinois. ALSO

PARCEL 2: Easement for the benefit of Parcel 1 for parking and ingress and egress as created by agreement made by and between LaSalle National Bank, Trustee, Trust No. 104789 and Pioneer Bank and Trust Company, Trustee, Trust No. 22505, recorded December 14, 1983 as Document No. 871353, over the following described land: The West 200 feet of Lot 2 in Berkshire Drive Re-subdivision, being a subdivision of part of Lots 14 and 15 in Plat of Farms at Crystal Lake, being a subdivision of part of Section 8, Township 43 North, Range 8 East of the Third Principal Meridian, according to the Plat thereof recorded December 20, 1976 as Document No. 682403, in McHenry County, Illinois.

commonly known as 19 E. Berkshire Drive, Crystal Lake, Illinois.

SECTION II: Said Special Use is issued with the following conditions:

1. Plans approved by the City Council, with changes reflecting staff and advisory board recommendations:

- A. Application (Lazer Extreme, LLC, received 03/01/02).
- B. Plat of Survey (Chicagoland Survey Co., received 03/01/02).
- C. Floor Plan Set (Elmore and Associates, dated 02/21/02).
- D. Wall Sign Elevation (Hughes Sign Co., dated 03/06/02).

2. Floor Plan Set (Elmore and Associates, dated 02/21/02).
  - A. Provide a more detailed layout for the arcade and the laser tag arena to the Planning Department in order to ensure that the intensity of the use does not increase beyond a level than what is intended by this Special Use Permit.
  
3. If the petitioner intensifies the use of the facility, which in turn, requires more parking than is provided, then the petitioner must seek a Special Use Permit Amendment and additional Variations for parking.
  
4. The petitioner shall work with the owner to paint and/or maintain the bleached and faded areas on the east (front) mansard roof to match the balance of the shopping center.
  
5. The petitioner shall work with the owner to repair or replace the existing fence along the south property line.
  
6. The petitioner shall work with the owner to re-stripe all parking spaces within the shopping center. Two handicapped parking spaces must be provided.
  
7. All trash and litter along the south and west sides of the shopping center must be cleaned up prior to occupancy.
  
8. The following Zoning Ordinance Variation is hereby granted:
  - A. Section 5.3-5.4 for required parking, to allow 28 parking spaces for the proposed use, in lieu of the required 29 parking spaces, a Variation of 1 parking space.
  
9. The petitioner shall address all of the review comments of the Building, Fire/Rescue, Police and Planning Departments.

Section III: That the City Clerk be and is hereby directed to amend the official zoning map of the City of Crystal Lake and all pertinent records of the City of Crystal Lake to show the issuance of a Special Use Permit in accordance with the provisions of this Ordinance, as provided by law.

Section IV: That this Ordinance shall be in full force and effect from and after its passage and approval as provided by law.

AYES: 7

NAYS: 0

ABSTENTIONS: 0

ABSENT: 0

PASSED this 16th day of April, 2002.

APPROVED by me this 16th day of April 2002

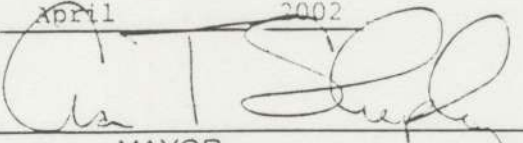
  
\_\_\_\_\_  
MAYOR

ATTEST:

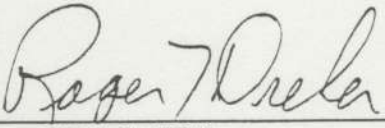
  
\_\_\_\_\_  
CITY CLERK

Published in pamphlet form by the authority of the Mayor and City Council of the City of Crystal Lake.