

MOUNTABLE CURB DIMENSIONS FOR "G" AND "C"		
CURB TYPE	"G" (INCHES)	"C" (INCHES)
TYPE M-3.24	24	3
TYPE M-4.12	12	4
TYPE M-6.06	6	6
TYPE M-6.12	12	6
TYPE M-6.18	18	6
TYPE M-6.24	24	6

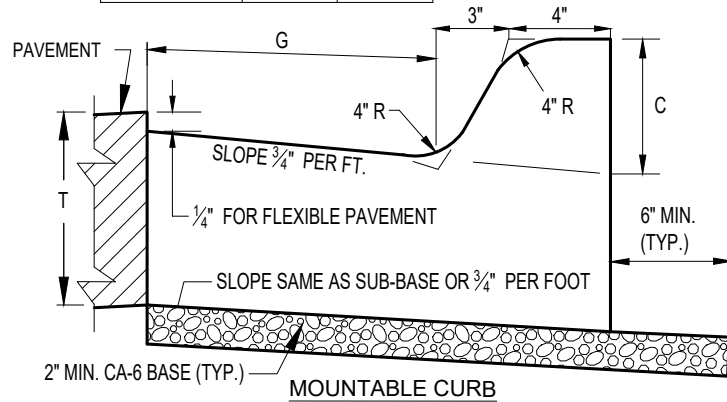

**NOTES:**

**THICKNESS - T -** THICKNESS OF PAVEMENT WHEN CURB AND GUTTER IS CONSTRUCTED ADJACENT TO FLEXIBLE OR RIGID PAVEMENT, THE VERTICAL THICKNESS OF THE GUTTER FLAG SHALL BE 9". ALSO, TIE BARS SHALL BE OMITTED.

**DRAINAGE OPENINGS -** AT ALL LOCATIONS WHERE METAL CASTINGS ARE TO BE INCORPORATED IN THE CURB AND GUTTER, A 1" THICK PRE FORMED EXPANSION JOINT FILLER, CONFORMING TO THE CROSS SECTIONS OF THE CURB AND GUTTER, SHALL BE INSTALLED IN THE CURB AND GUTTER A DISTANCE OF 5 FT. FROM EACH SIDE OF THE METAL CASTING. WHEN THE WIDTH OF THE METAL CASTING IS LESS THAN THE WIDTH OF THE CURB AND GUTTER, 2 - NO. 4 REBARS (L = 12 + CASTING LENGTH = 12") SHALL BE INCORPORATED IN THE CONTINUOUS OF CONCRETE GUTTER IN FRONT OF THE CASTING.

**TRANSITIONS -** THE TRANSITION FROM FULL HEIGHT CURB TO DEPRESSED CURB SHALL BE MADE AT THE RATE OF 3" PER FOOT OF LENGTH OR FLATTER.

(2) - NO. 4 STEEL REINFORCING BARS SHALL BE INCORPORATED OVER TRENCH CROSSINGS IF REQUIRED BY THE CITY ENGINEER.

**JOINTS -** IN ADDITION TO THE REQUIREMENTS OF ARTICLE 606.06 OF THE STANDARD SPECIFICATIONS, JOINTS SHALL BE CONSTRUCTED AS FOLLOWS:

BARRIER CURB DIMENSIONS FOR "G" AND "C"		
CURB TYPE	"G" (INCHES)	"C" (INCHES)
TYPE B-6.12	12	6
TYPE B-6.18	18	6
TYPE B-6.24	24	6
TYPE B-9.12	12	9
TYPE B-9.18	18	9
TYPE B-9.24	24	9

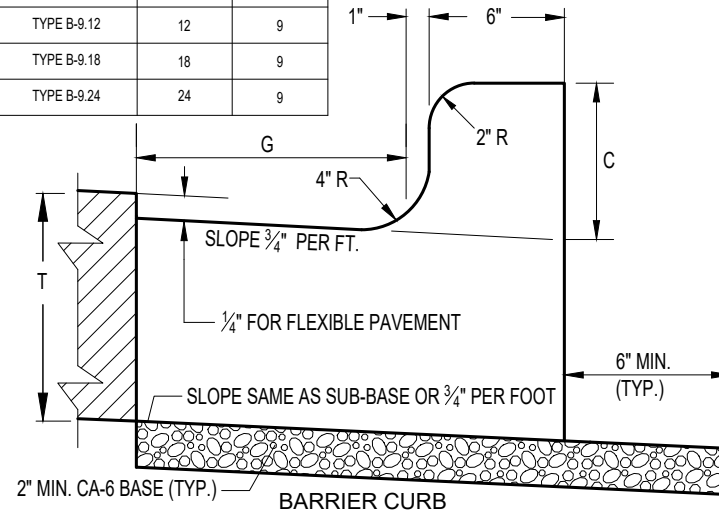

CONTRACTION JOINTS AND EXPANSION JOINTS SHALL BE INSTALLED IN THE CURB OR CURB AND GUTTER IN PROLONGATION WITH JOINTS IN ADJACENT P.C.C. PAVEMENT OR BASE COURSE.

WHEN CURB AND GUTTER IS CONSTRUCTED ADJACENT TO FLEXIBLE PAVEMENT, A 1" THICK PRE FORMED EXPANSION JOINT FILLER, CONFORMING TO THE CROSS SECTION OF THE CURB AND GUTTER, SHALL BE INSTALLED AT POINTS OF CURVATURE FOR SHORT RADIUS CURVES AND AT CONSTRUCTION JOINTS. CONTRACTION JOINTS SHALL BE PLACED BETWEEN EXPANSION JOINTS AT DISTANCES NOT TO EXCEED 15 FEET.

ALL EXPANSION JOINTS SHALL BE PROVIDED WITH A 1 1/2" DIA. X 18" COATED SMOOTH DOWEL BAR CONFORMING TO ARTICLE 1006.10 OF THE STANDARD SPECIFICATIONS. THE DOWEL BAR SHALL BE FITTED WITH A CAP HAVING A PINCHED STOP THAT WILL PROVIDE 1" OF EXPANSION.

ALL CONSTRUCTION JOINTS SHALL BE PROVIDED WITH 1/2" DIA. DEFORMED STEEL TIE BARS 30" LONG CONFORMING TO AASHTO M-31 OR M-53. TIE BARS SHALL BE PLACED ON 9" CENTERS (MINIMUM 2 PER JOINT).

EXPANSION JOINTS SHALL BE PLACED AT INTERVALS NOT TO EXCEED 100 FEET.

Revised:
1. 06/12/2015
2. KL 1/25/2021 M-4.12 ADDED
3.
4.

Drawing Name

## CURB: CONCRETE CURB AND GUTTER

Drawing Number	RD-05a
Date:	08/21/2018
Drawn	Checked
DD	AW



City of  
**Crystal Lake**  
Illinois